

Rinnai

Operation / Installation

Manual

RINNAI 'PRESTIGE'[®] and RINNAI 'SUNMASTER'[®]

Solar Split Systems Electric and Gas Boosted

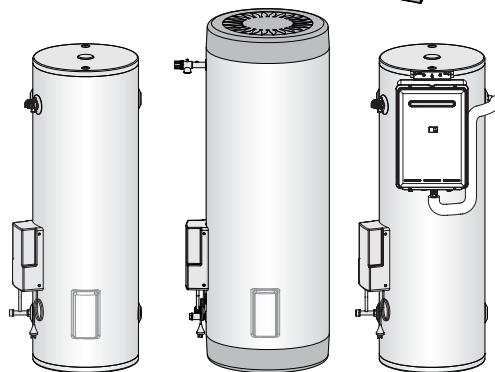
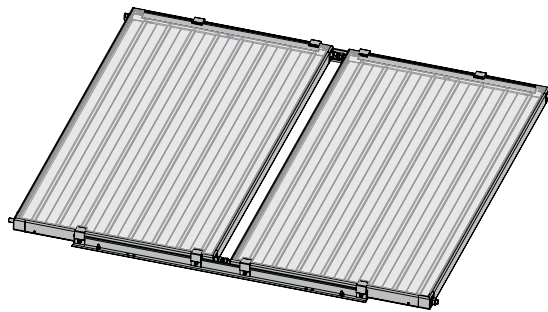

NOTE

The appliance must be installed, commissioned and serviced by an authorised person in accordance with all applicable local rules and regulations.



WARNING

The collector flow and return pipes should be 15mm copper tube or alternative tube supplied by Rinnai. Plastic pipe must not be used. Plastic pipe is not suited to the high water temperatures and pressures that may occur in the collector flow and return system.

NOT SUITABLE AS A POOL OR SPA HEATER



The Australian Gas Association
All Rinnai gas products
are A.G.A. certified.



N10378

Certified Product



WaterMark
AS3498 Lic W169
SAI Global

Certified Product



WaterMark
AS3498 Lic W208
SAI Global



AS 2712
Lic No.1849
SAI Global



Quality Endorsed Company

ISO 9001 Lic 4983
SAI Global

Head Office Certified

Distributed and serviced in Australia under a Quality System certified as complying with ISO 9001 by SAI Global

15401021

TABLE OF CONTENTS

IMPORTANT INFORMATION & WARNINGS.....	2
SAFETY & REGULATORY INFORMATION.....	2
SCALDS HAZARDS	3
OPERATION PRINCIPLE	4
SAFETY DEVICES.....	5
EXCESSIVE DISCHARGE FROM SAFETY DEVICES	5
WATER TEMPERATURE.....	6
TURNING 'OFF' THE WATER HEATING SYSTEM	6
TURNING 'ON' THE WATER HEATING SYSTEM.....	6
WATER QUALITY	7
DRAINING AND FILLING THE WATER HEATING SYSTEM	7
MAINTENANCE AND REGULAR CARE	7
SERVICING AND REPAIR.....	7
SAVE A SERVICE CALL	8
SPECIFICATIONS FOR SYSTEMS.....	10
GENERAL	10
SYSTEM SPECIFICATIONS AND DIMENSIONS	10
FLOW CONTROL VALVE	10
DIFFERENTIAL TEMPERATURE CONTROLLER.....	10
SPECIFICATIONS FOR SOLAR COLLECTORS.....	11
SPECIFICATIONS FOR STORAGE CYLINDERS.....	12
SPECIFICATIONS FOR GAS BOOSTERS	15
INSTALLATION & MAINTENANCE - ALL SYSTEMS	16
REGULATIONS AND OCCUPATIONAL HEALTH AND SAFETY (OH&S)	16
LOCATION - GENERAL INFORMATION	16
STORAGE CYLINDER LOCATION	16
GAS BOOSTER LOCATION AND MOUNTING (where applicable)	17
WATER PIPES	17
WATER SUPPLY.....	17
HOT WATER DELIVERY TEMPERATURE.....	17
VALVES & FITTINGS	18
INSTALLATION OF SOLAR COLLECTORS	18
REGULATIONS AND OCCUPATIONAL HEALTH AND SAFETY (OH&S)	19
SYSTEM ORIENTATION AND INCLINATION	19
SOLAR COLLECTOR ROOF MOUNTING OPTIONS	20
SOLAR COLLECTOR INSTALLATION COMPONENTS	21
STANDARD INSTALLATION.....	22
FRAMED INSTALLATIONS - FLAT ROOF FRAMES.....	25
FRAMED INSTALLATIONS - CYCLONE FRAME.....	26
COMMERCIAL INSTALLATIONS	26
COLLECTOR FITTINGS INSTALLATIONS.....	29
INSTALLATION & MAINTENANCE - GAS BOOSTED SYSTEMS	35
OVERVIEW OF SYSTEM COMPONENTS	31
GAS BOOSTER LOCATION	31
GAS SUPPLY.....	31
HOT WATER DELIVERY TEMPERATURE.....	31
CLEARANCES.....	31
GAS BOOSTER MOUNTING.....	31
INSTALLATION PROCEDURE	43
FILLING THE SYSTEM.....	44
CHECKING SOLAR PUMP OPERATION.....	45
ADJUSTING FLOW CONTROL VALVE	45
PRE SOLAR HEATING CHECKS	45
SOLAR HEATING	47
FINISHING THE INSTALLATION	47
DRAINING INSTRUCTIONS.....	47
INSTALLATION & MAINTENANCE - ELECTRIC BOOSTED SYSTEMS	48
OVERVIEW OF SYSTEM COMPONENTS	48
ELECTRIC SUPPLY.....	48
HOT WATER STORAGE AND DELIVERY TEMPERATURES	48
INSTALLATION PROCEDURE	55
FILLING THE SYSTEM.....	58
CHECK SOLAR PUMP OPERATION	58
ADJUSTING FLOW CONTROL VALVE.....	58
PRE SOLAR HEATING CHECKS	59
SOLAR HEATING	59
FINISHING THE INSTALLATION	59
DRAINING INSTRUCTIONS.....	60
CONTACT INFORMATION.....	61

IMPORTANT INFORMATION & WARNINGS

SAFETY & REGULATORY INFORMATION



DO NOT operate this system before reading the manufacturers instructions.

This appliance must be installed, commissioned and serviced by an authorised person in accordance with all applicable local rules and regulations.

Access covers of water heating system components will expose 240V wiring and **MUST** be removed by an authorised person.

This appliance is not intended for use by persons (including children) with reduced physical, sensory or mental capabilities, or lack of experience and knowledge, unless they have been given supervision or instruction concerning use of the appliance by a person responsible for their safety.

For continued safety of this appliance it must be installed, operated and maintained in accordance with the manufacturers instructions.

Children should be supervised to ensure they **DO NOT** play with the appliance.

Any power leads from the water heater system components **MUST BE** plugged into an external weatherproof electrical outlet. If the power supply cord of any water heating components is damaged, it **MUST BE** replaced by an authorised person in order to avoid a hazard, using genuine replacement parts available from Rinnai. Take care not to touch the power plugs with wet hands.

Care should be taken not to touch the pipe work as it may be **HOT!** The pipes between the solar collectors and storage cylinder **MUST BE** copper, or alternative material pipes that may be supplied by Rinnai. Plastic pipe is **NOT** suited to the water temperatures and pressures that may occur in the system.

DO NOT place articles on or against this appliance.

DO NOT store chemicals or flammable materials near this appliance.

DO NOT operate with collectors or covers removed from this appliance.

DO NOT activate pump unless cylinder is full of water.

NEVER use a flammable spray such as hair spray, lacquer, paint, etc near this unit as this may cause a fire.

NOTICE TO VICTORIAN CONSUMERS

This appliance must be installed by a person licensed with the Plumbing Industry Commission.

Only a licensed person will have insurance protecting their workmanship.

So make sure you use a licensed person to install this appliance and ask for your Compliance Certificate.

For Further information contact the Plumbing Industry Commission on 1800 015 129.

IMPORTANT INFORMATION & WARNINGS

SCALDS HAZARDS



HOT WATER CAN CAUSE SCALDS.

CHILDREN, DISABLED, ELDERLY AND THE INFIRM ARE AT THE HIGHEST RISK OF BEING SCALDED.

FEEL WATER TEMPERATURE BEFORE BATHING OR SHOWERING.

SCALDS FROM HOT WATER TAPS CAN RESULT IN SEVERE INJURIES TO YOUNG CHILDREN.

SCALDS OCCUR WHEN CHILDREN ARE EXPOSED DIRECTLY TO HOT WATER WHEN THEY ARE PLACED INTO A BATH WHICH IS TOO HOT.

ALWAYS.....

Test the temperature of the water with your elbow before placing your child in the bath, also carefully feel water before bathing or showering yourself.

Supervise children whenever they are in the bathroom.

Make sure that the hot water tap is turned off tightly.

CONSIDER.....

Installing child proof tap covers or child resistant taps (both approaches will prevent a small hand being able to turn on the tap).

Installing tempering valves or thermostatic mixing valves which reduce the hot water temperature delivered to the taps. Your local plumbing authority may already require that these be fitted. Contact your installer or local plumbing authority if in doubt.

NEVER.....

Leave a toddler in the care of another child. They may not understand the need to have the water temperature set at a safe level.

IMPORTANT INFORMATION & WARNINGS

OPERATION PRINCIPLE

This system is designed to have the solar collectors on the roof and the storage cylinder installed at ground or floor level. Electric and Gas boosted models are available. The system comprises a hot water storage cylinder, solar collectors, pump circulation system solar control unit and temperature sensors. The solar control unit ensures water circulates between the solar collectors and the storage cylinder to transfer heat from the solar collectors to the water in the cylinder if enough heat is available from the sun.

Supplementary heating is provided if insufficient heat is available from sun (such as during cloudy or rainy weather or during winter months) either via an electric heating element(s) located inside the storage cylinder or via a on-line Gas booster located external to the storage cylinder. The following diagrams illustrates the Split Solar Hot Water System set up for both the Electric and Gas boost..

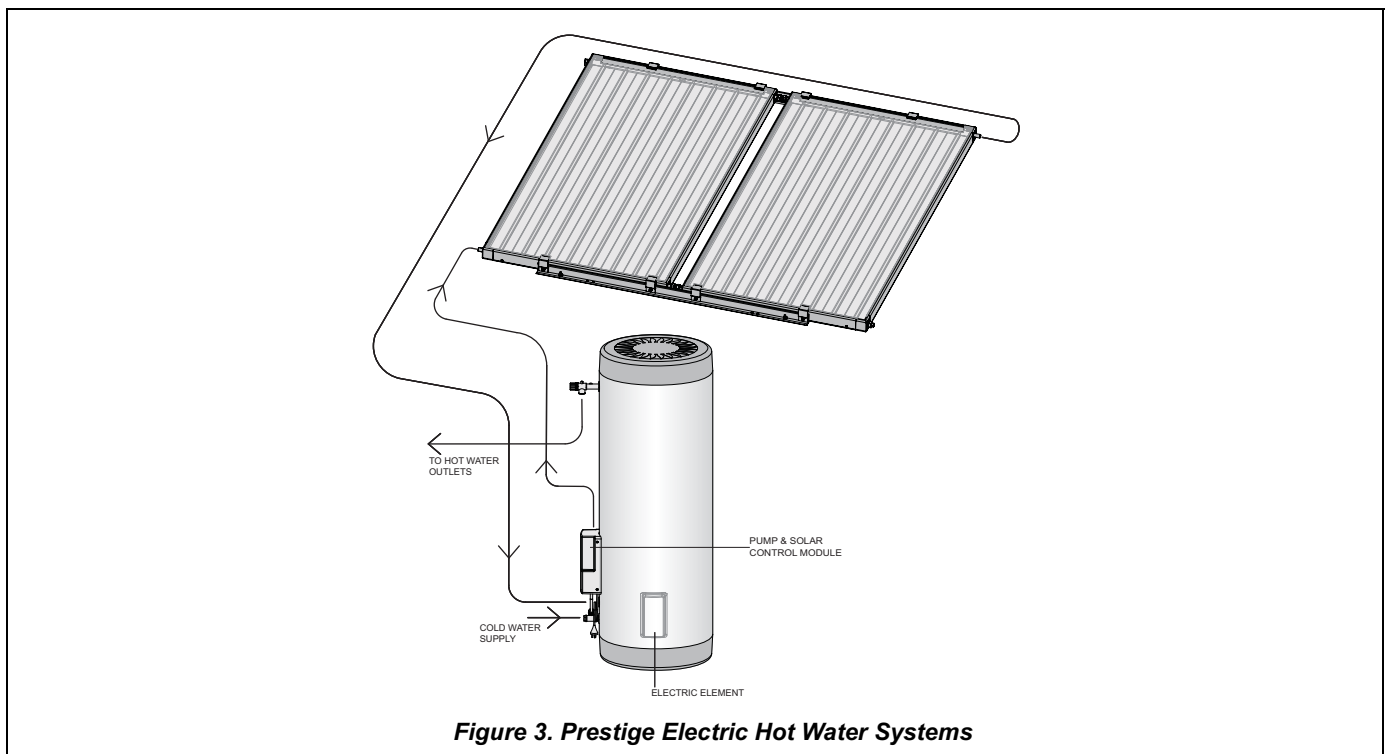
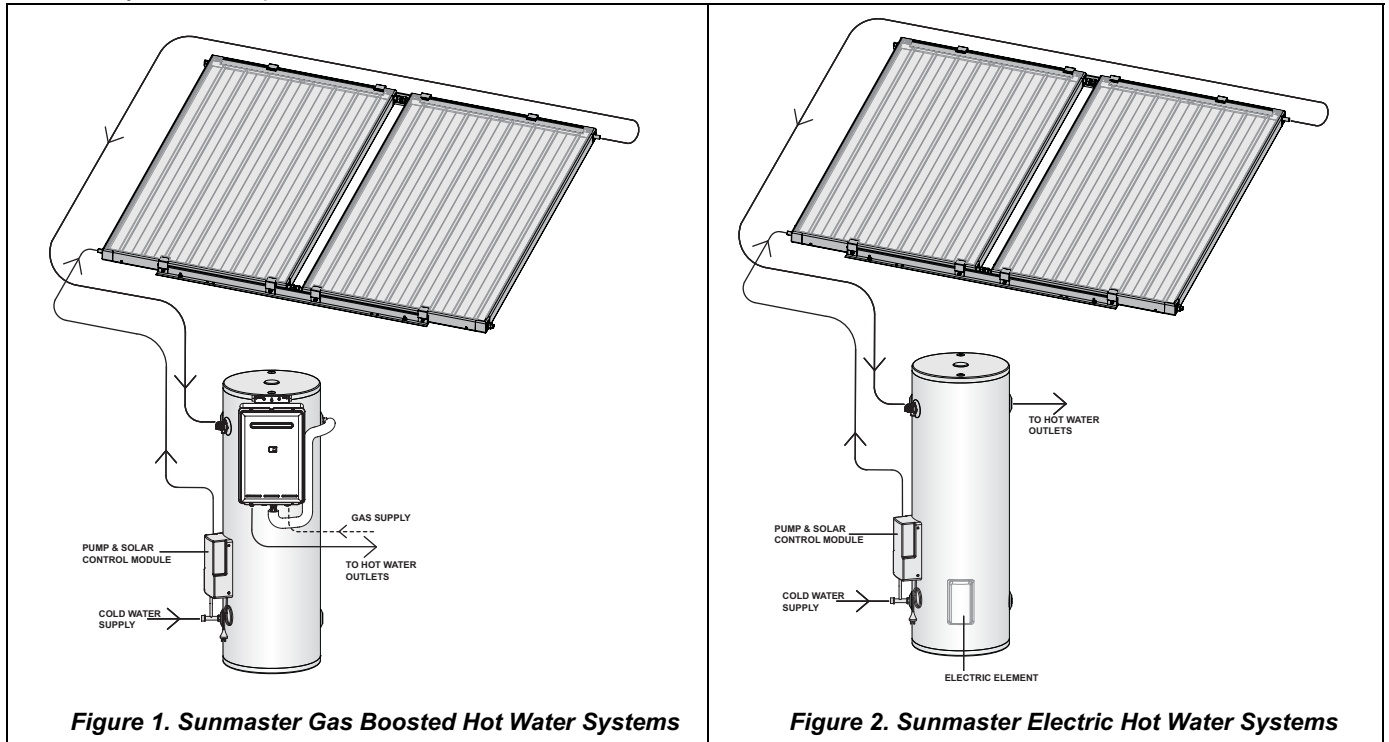

IMPORTANT INFORMATION & WARNINGS

SAFETY DEVICES

The water heating system is supplied with various safety devices including temperature sensors, overheat sensors and switches and a Pressure & Temperature Relief (PTR) valve. These devices must not be tampered with or removed. The water heating system must not be operated unless each of these devices is fitted and is in working order.



DO NOT tamper with or remove safety devices.

DO NOT operate the water heater unless all safety devices are fitted and in working order.

DO NOT block or seal the PTR Valve and drain pipe.

Pressure & Temperature Relief (PTR) Valve

This valve is located near the top of the water heater and is essential for safe operation. It is normal for the valve to release a small quantity of water through the drain line during heating.

However, continuous leakage of water from the valve and its drain line may indicate a problem with the water heater.

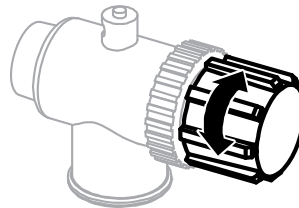

Twist cap until water flows from drain line

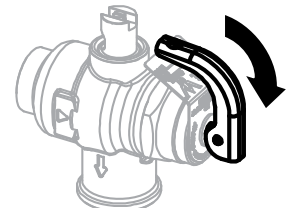

Lift lever until water flows from drain line (Lower lever gently!)



Never block the outlet of the PTR valve or its drain line for any reason. The easing gear must be operated at least every 6 months to remove lime deposits and verify that it is not blocked. Failure to do this may result in the water heater failing.

If the valve does not discharge water when the easing gear lever is opened, or does not seal again when the easing gear is closed, attendance by an authorised person must be arranged without delay. The PTR valve is not serviceable.

EXCESSIVE DISCHARGE FROM SAFETY DEVICES

Pressure & Temperature Relief (PTR) Valve

It is normal and desirable that this valve allows a small quantity of water to be discharged during the heating cycle. If it discharges more than a bucket of water during a 24 hour period or discharges continuously there may be another problem.

If the valve dribbles continuously, try easing the valve gear for a few seconds as described above. This may dislodge any foreign matter and alleviate the problem.

If the valve discharges at high flows, especially at night, it may be as a result of the water pressure exceeding the design pressure of the water heater. Ask your installer to fit a Pressure Limiting Valve (PLV).



NEVER replace the PTR valve with one which has a higher pressure rating than is specified for your water heater.

Expansion Control Valve (ECV) - if fitted

It is normal and desirable that this valve allows a small quantity of water to be discharged during the heating cycle. If it discharges more than a bucket of water during a 24 hour period or discharges continuously there may be another problem.

If the valve leaks continuously, try easing the valve gear for a few seconds. This may dislodge any foreign matter and alleviate the problem. If this does not alleviate the problem contact Rinnai.

Operate the easing gear regularly to remove any lime deposits and to verify that it is not blocked.

IMPORTANT INFORMATION & WARNINGS

Gas boosted models

- Do not touch the flue outlet or do not insert any objects into the flue outlet.
- Keep flammable materials, spray cans, fuel containers, trees, shrubs and pool chemicals etc. well clear of the flue outlet.
- Do not use the gas types other than those designated on the data plate. For example, do not use Propane/Butane gas mixtures on appliances marked Propane Gas.
- Do not use Propane gas on appliances marked as Natural gas and vice versa.

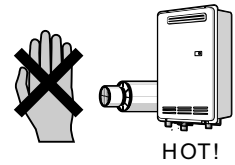

Hydrogen Gas

In the case of systems using a vitreous enamelled lined cylinder, if the hot water unit is not used for two weeks or more, a quantity of hydrogen gas, which is highly flammable, may accumulate in the water heater. To dissipate this safety, it is recommended that a non electrically operated hot tap be turned on for two minutes at a sink, basin, or bath, but not a dishwasher or other appliance. during this procedure there must be no smoking, open flame or any electrical appliance operating nearby. If hydrogen is discharged through the tap, it will probably make a sound like air escaping.

WATER TEMPERATURE

The solar control unit and pump ensure water circulates between the solar collectors and storage cylinder until the water at the base of the cylinder reaches approximately 65°C. Under these conditions water at the hot outlet may exceed 85°C. During periods of low solar gain supplementary heating occurs to a minimum of 60°C as required.



To meet Australian regulatory requirements, supplementary heating temperature settings must be at least 60°C.

TURNING 'OFF' THE WATER HEATING SYSTEM

If you plan to be away for only a few nights, we suggest you leave the water heating system switched on. If it is necessary to switch off the water heater, do so as outlined below:

Electric Boosted systems

- Switch off the electric supply to the supplementary heating element. The switch is usually marked and located in the electricity meter box of the dwelling.
- Switch off the electric supply to the solar controller and pump.

Gas Boosted systems

- Switch off the electric supply to the gas booster.
- Switch off the electric supply to the solar controller and pump.

TURNING 'ON' THE WATER HEATING SYSTEM

Electric Boosted system

- Switch on the electric supply to the supplementary heating element(s). The switch is usually marked and located in the electricity meter box of the dwelling.
- Switch on the electric supply to the solar controller pump. Electric and solar water heating will now occur as required. It may take a number of hours before hot water is available.

Gas Boosted systems

- Switch on the electric supply to the gas booster.
- Switch on the electric supply to the solar controller and pump. Solar water heating will now occur. Hot water is available immediately from the gas booster when hot water tap is opened, irrespective of solar heat gain.

IMPORTANT INFORMATION & WARNINGS

WATER QUALITY

The water quality of most public supplies is suitable for the water heating system. The water quality from bore wells is generally unsuitable for the water heating system. Refer to separate 'Warranty Terms and Conditions' document for water quality parameters and how they affect the warranty conditions. If in doubt about the water quality, have it checked against the parameters listed in the warranty conditions. The system is not suitable as a pool or spa heater.

DRAINING AND FILLING THE WATER HEATING SYSTEM

- Draining or filling normally occur only during installation or servicing and must be carried out by an authorised person.

MAINTENANCE AND REGULAR CARE

Operate the easing gear of the PTR as described under "" on page 4.

The overflow tray (supplied by installer) and drain underneath the storage cylinder (if fitted) should be periodically checked to ensure there are no blockages.

SERVICING AND REPAIR

Our Servicing network personnel are fully trained and equipped to give the best service on your appliance. If your appliance needs service, ring one of the service contact numbers on the back of this booklet.

It is recommended that the system be serviced at least every 5 years.

The pressure and temperature relief valve and expansion control valve must be checked for performance or replaced by an authorised person at intervals not exceeding 5 years or more frequently in areas where the water is classified as scaling water (refer to 'Warranty Terms and Conditions' document - 'Water Quality').

It is recommended that the sacrificial anode fitted to Sunmaster cylinders be inspected every 5 years or more frequently in areas where there is a high incidence of water deposits. This does not apply to Rinnai Prestige cylinders. Anodes suited to hard and soft water, are available from Rinnai.

If the electric conduit, power supply cord or plug to the water heater is damaged, they must be replaced by an authorised person in order to avoid a hazard. The power supply cord and plug (if fitted) must be replaced by a genuine replacement part available from Rinnai.

SAVE A SERVICE CALL

Table 1 - Troubleshooting

Problem	Cause	Remedy
Insufficient or no hot Water	Booster heating not operating Or Insufficient gas supply for gas boosted heating system	<p>Electric boosted Systems: Check to ensure the electric isolating switch(es) at the switchboard (usually marked "Hot water" or "water heater") is switched 'ON'. Check to ensure that the electric fuses for hot water at the switchboard are intact.</p> <p>Gas Boosted Systems: Check to ensure the power cord of the gas booster is plugged in and the power point switched 'ON'. Check gas is available and turned ON'. Close the hot tap and wait for 10 seconds and open it again. The hot tap must be opened enough to ensure that the flow rate is not less than 2.4 L/min. gas the gas booster burners will not light if it is less than 2.4 L/min. Check the isolation valve in the gas line is opened. If there is gas supply to other appliances in the rest of the house, try lighting another gas appliance. Refer to your plumber to ensure the gas line has been purged of air after installation.</p>
	Excessive hot water consumption	<p>Electric Boosted Systems: If the water goes cold, are you using more hot water than you think? Often end users are surprised at the amount of hot water used, especially when showering. If the amount of hot water used during the day exceeds the storage capacity of the cylinder, it is likely that there will be insufficient hot water. Has your plumber install water saving fixtures and/or flow control or pressure limiting valves to reduce consumption.</p> <p>Gas Boosted Systems: Insufficient flow may occur if multiple outlets are in use at the same time and exceed the rated flow capacity of the gas booster. If so, reduce the number of outlets in use. Have your plumber install water saving fixtures and/or flow control or pressure limiting valves to reduce consumption. Check correct size gas booster is fitted.</p>
	Incorrect Solar system size	Do you have the correct system size and configuration for your requirements? Refer to Rinnai literature for information.
	Temperature and pressure relief valve / Expansion Control valve discharging water continuously	<p>Pressure and Temperature Relief (PTR) valve It is normal and desirable that this valve allows a small quantity of water to be discharged during the heating cycle. If it discharges more than a bucket of water during a 24 hour period or discharges continuously there may be another problem. If the valve dribbles continuously, try easing the valve gear for a few seconds as described under 'Regular Care'. This may dislodge any foreign matter and alleviate the problem. If the valve discharges at high flows, especially at night, it may be as a result of the water pressure exceeding the design pressure of the water heater. Ask your installer to fit a Pressure Limiting Valve (PLV).</p>
 WARNING	<ul style="list-style-type: none"> • Never replace the PTR valve with one which has a higher pressure rating than is specified for your water heater. • If the valve discharges hot water at high flows, (dumps) there may be a serious problem. Switch off the power supply in the meter box (the switch marked 'WATER HEATER' or 'HOT WATER') or the isolating switch installed near the water heater and contact Rinnai. 	
Insufficient or no hot Water Continued		<p>Expansion Control Valve (ECV) - if fitted It is normal and desirable that this valve allows a small quantity of water to be discharged during the heating cycle. If it discharges more than a bucket of water during a 24 hour period or discharges continuously there may be another problem. If the valve leaks continuously, try easing the valve gear for a few seconds as described under 'Regular Care'. This may dislodge any foreign matter and alleviate the problem. If this does not alleviate the problem contact Rinnai.</p>

SAVE A SERVICE CALL

Problem	Cause	Remedy
Insufficient or no hot Water continued	Booster element Thermostat Settings	<p>Electric Boosted Systems: The end user can check the temperature of hot water delivered with a thermometer placed under the closest non tempered outlet (usually the kitchen sink). CAUTION: Take care to avoid scalding. This test should be done early in the morning after overnight electrical boosting before any hot water is used. The temperature of the water delivered should be at least 55° C (allowing for heat losses in pipe work). If this is not the case or the temperature needs to be increased contact Rinnai. The thermostat settings of the heating element thermostat can also be confirmed directly by a qualified person as described under 'hot water storage & delivery temperature'. The settings can be increased if required. Contact Rinnai.</p> <p>Gas Boosted Systems: The delivery temperature of gas boosted systems is normally 60 or 65°C. If temperatures are higher than this, the flow of water through the gas booster will reduce and may result in insufficient flow rate. The end user can check the temperature of hot water delivered with a thermometer placed under the closest outlet (usually the kitchen sink). CAUTION: Take care to avoid scalding. If the temperature is higher than 65°C the gas booster may be preset incorrectly. Contact Rinnai.</p>
No Water from the hot tap	Restriction in the hot tap or failure of the cold water supply to the water heater.	Check for water flow at the other taps and that the cold water isolation is fully open.
Gas Booster operating too frequently	Insufficient Sunlight - Collectors shaded	Ensure the trees or other objects are not shading onto the collector surface (Trim the trees or relocate the solar collector if the obstruction is permanent). Make sure the glass on the collector is not dirty.
High electricity or gas bill	Excessive hot water consumption	See entry under 'Insufficient hot water'.
	Solar Control unit switched off	If the solar control unit is switched off there will be no solar pre-heating of water resulting in the water being heated entirely by electricity or gas' boosting'. Check the power outlet for the solar control unit is switched on.
	Temperature and pressure relief valve / Expansion Control valve discharging water continuously	See entry under 'Insufficient hot water'.
	Lack of solar gain	<p>Reduced sunlight: Reduced sunlight due to overcast weather in summer or low solar contribution in winter will result in an increased dependence on electricity or gas boosting. Higher electricity or gas bills under these conditions, especially in winter, are normal.</p> <p>Collectors shaded: If the solar collectors are shaded by trees or other objects, or the glass is dirty, the effectiveness of the collectors is greatly reduced. Arrange for trimming of the trees or relocation of the solar collectors if the obstruction is permanent. Arrange for cleaning of the collector glass.</p> <p>Solar collectors incorrectly positioned Check that positioning and alignment of solar collectors is in accordance with the section 'Location and alignment of solar collectors'. WARNING: Persons working from elevated surfaces such as roofs must be adequately trained and qualified in accordance with local OH&S requirements.</p>
	High Electricity Tariffs (electric boosted systems only)	<p>Electric Boosted Systems The electricity tariff will determine the running costs of the system. It is important the end user is aware of the applicable tariffs. Contact your electricity supplier to confirm what these tariffs are.</p>
	Little or no water circulation in the solar 'flow and return' loop	There are numerous causes of little or no circulation in the solar 'flow and return' circuit the circulation of water through the collectors. These causes must be investigated by a qualified person. Contact Rinnai.
Water flow fluctuations	One or more hot taps opened at the same time	<p>More than one or two hot taps in use at the same time may cause a decrease in the hot water flow from the taps.</p> <p>Is there more than one or two hot taps open, or are appliances such as a dishwasher or washing machine, in use at the same time?</p> <p>Ensure only one or two hot taps are on at one time.</p> <p>Check the flow of the water from one tap, eg. the shower. The shower should be adjusted so the hot tap is fully open.</p>
Water Hammer	Hot and cold water plumbing in the premises	Have a plumber check clipping of hot and cold water pipework and install a pressure limiting valve and water hammer arrestor as required.

SPECIFICATIONS FOR SYSTEMS

GENERAL

Split solar hot water systems are specified according to the grade of storage cylinder material, cylinder capacity, number of solar collectors and boost type and capacity. Boost capacity for gas boosted system depends on the gas booster model selected. Boost capacity for electrically boosted systems depends on the power rating of electric heating elements and whether one or two electric heating elements are fitted.

SYSTEM SPECIFICATIONS AND DIMENSIONS

Specifications and principal dimensions for the various systems and components are shown below.

System Type	Rinnai 'Sunmaster' Systems SG175, SG215, SE160, SE200	Rinnai 'Sunmaster' Systems SG270, SG340, SE315	Rinnai 'Prestige' Systems
Connections:			
Solar flow and return	1/2"	1/2"	1/2"
PTR Valve	1/2"	1/2"	3/4"
Cold Inlet	3/4"	3/4"	3/4"
Hot Outlet	3/4"	3/4"	3/4"
PTR Valve setting (kPa)	1000	850	850
Rating of PTR Valve supplied (kW)	10	10	10
Expansion Control Valve (ECV) setting (kPa)	850	700	700
Max supply pressure with ECV (kPa)	680	550	560
Max supply pressure without ECV (kPa)	800	680	700
Pressure limiting valve rating (kPa) (supplied by installer if required)	500	500	500

FLOW CONTROL VALVE

A flow control valve is fitted to the pump and controller assembly.

It's purpose is to allow the water flow rate through the collector collectors and storage cylinder to be controlled to optimise the performance of the system.

DIFFERENTIAL TEMPERATURE CONTROLLER

The primary task of the differential temperature controller is to control the operation of the pump to optimize solar energy collection. This task is performed by measuring the temperature differential between the hot sensor and the cold sensor. When the differential exceeds 9°C the pump is activated and water passes through the collectors collecting solar energy. When the differential falls below 5°C the pump is shut down.

A secondary task of the controller is to stop energy collection when the cylinder is full of hot water. This is referred to as no load protection and the pump is shut down if the temperature of the water going to the collectors exceeds 65°C. At such a temperature in the base of the cylinder, the temperature of water in the top of the cylinder is expected to be about 85°C.

SPECIFICATIONS FOR SOLAR COLLECTORS

Table 3 - Model Numbers and Specifications

MODEL NUMBERS AND SPECIFICATIONS

CHARACTERISTICS	Enduro / Equinox (SP200A) or (SP200A FTC)	Excelsior (EXT OR EXT FTC)	E-FROST (HPFTC- 8-10)
TYPE	Flat plate	Flat plate	Flat Plate / Heat Pipe
CONSTRUCTION			
- Waterways	Copper	Copper	Copper
- Absorber	Aluminium	Copper	Aluminium
- Selective Surface	High Performance	Sputtered Titanium Oxide	High Performance
Maximum Operating Pressure	850 kPa		
Casing Material	Aluminium		
Overall Dimensions (L x W x H) (mm)	1940 x 1025 x 80	1964 x 1047 x 81	1940 x 1025 x 80
Weight empty (STD/FTC) (kg).	33 / 35	35 / 38	34
Water volume (Litres)	1.3	1.5	0.6
Number risers	8	10	10
Potential Solar Output at PTR relief conditions (kW)	1.25		
Approximate Roof space Required: Length x Width			
- 1 Collector (mm)	1940 x 1025	1940 x 1047	1940 x 1025
- 2 Collectors (mm)	1940 x 2130	1940 x 2174	1940 x 2130
- 3 Collectors (mm)	1940 x 3235	1940 x 3301	1940 x 3235
Commercial Systems	Refer to Figure 23 for details		
Frost Protection	* Standard version - no frost protection Frost Protection to -5°C		*Frost protection to -12°C. Power must be on at the pump and controller must be in low temperature mode (factory default).
	* FOR MORE INFORMATION ON FROST PROTECTION REFER TO WARRANTY BOOKLET		

SPECIFICATIONS FOR STORAGE CYLINDERS

SUNMASTER - ELECTRIC - VITREOUS ENAMEL

	SE160	SE200	SE315
PTR / Solar Return / Hot Water Outlet	1310	1605	1200
Flow line to Collectors	665	665	700
Cold Water Inlet	225	225	260
Cylinder Height	1530	1825	1510
Diameter	515	515	685
Weight Empty (kg)	71	83	100

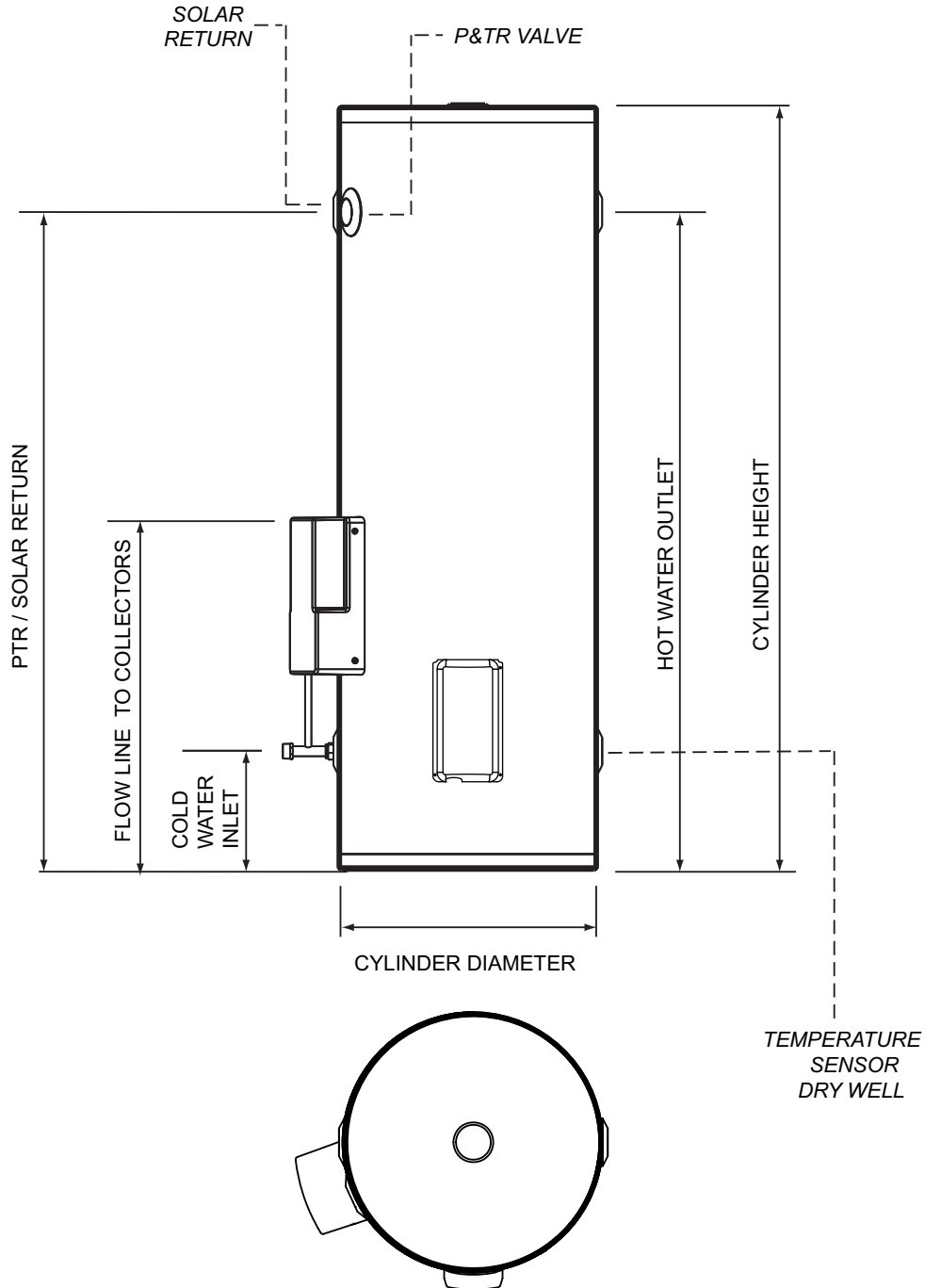

Figure 4 - Dimensional Drawing - Rinnai Sunmaster Vitreous Enamel Storage Cylinder - Electric Boosted Split Systems

SPECIFICATIONS FOR STORAGE CYLINDERS

SUNMASTER GAS - VITREOUS ENAMEL

	SG175	SG215	SG270	SG340
Cylinder Height	1530	1825	1265	1510
PTR / Solar Return	1310	1605	985	1200
Flow line to collectors	665	665	700	700
Cold Water Inlet	225	225	260	260
Gas Supply and Hot Water Outlet	940	1235	675	920
Gas Booster Flue Outlet	1400	1695	1135	1380
Diameter	515	515	685	685
Weight Empty (kg)	66	88	95	103

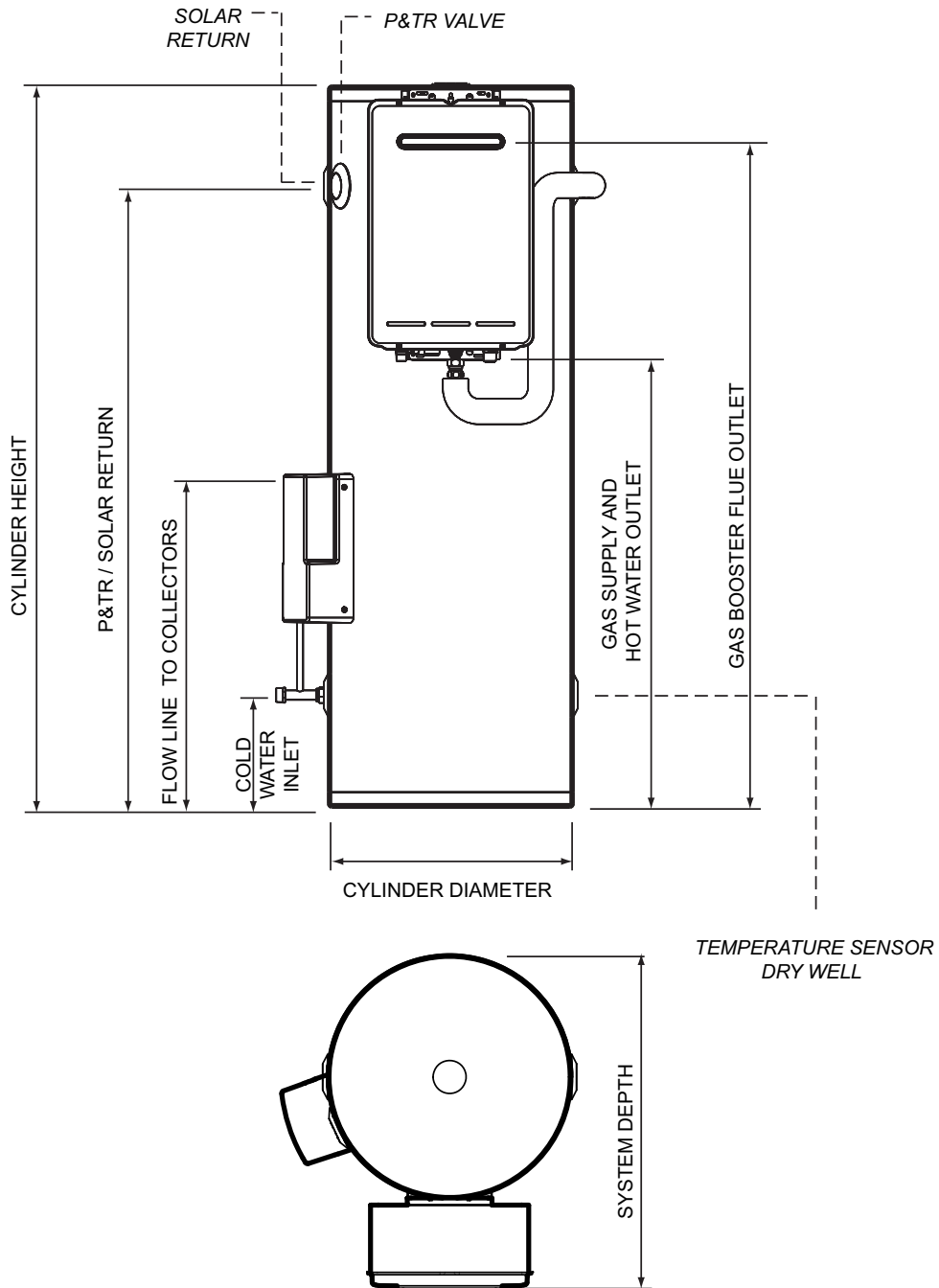
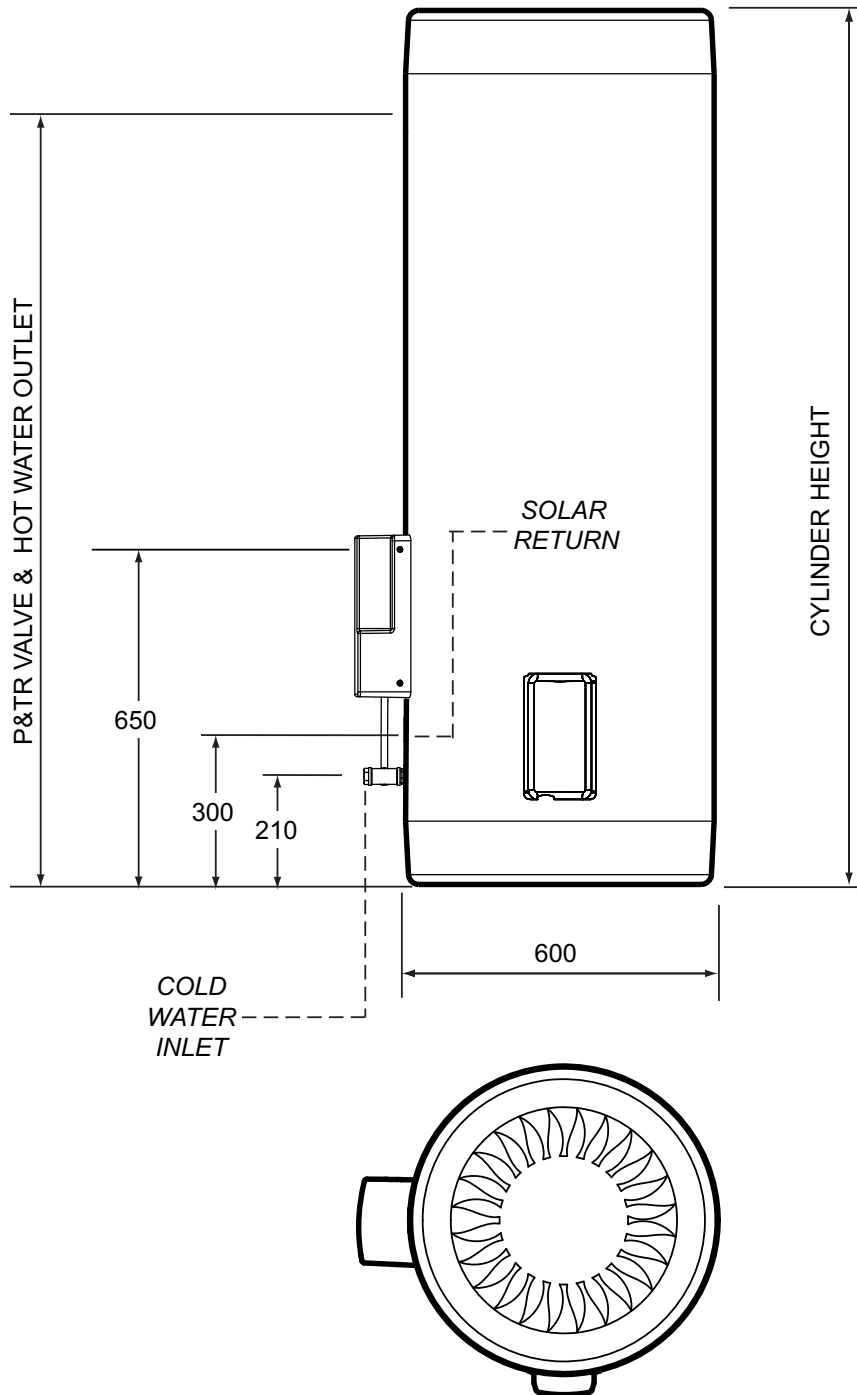

Figure 5 - Dimensional Drawing - Rinnai Sunmaster Vitreous Enamel Storage Cylinder - Gas Boosted Split Systems

SPECIFICATIONS FOR STORAGE CYLINDERS

PRESTIGE ELECTRIC - STAINLESS STEEL

PRESTIGE ELECTRIC	160	250	315
PTR / Solar Return / Hot Water Outlet	995	1490	1880
Cylinder Height	1205	1700	2090
Weight Empty (kg)	44	56	68



**Figure 6 - Dimensional Drawing - Rinnai Prestige Stainless Steel Storage Cylinder
- Electric Boosted Split systems**

SPECIFICATIONS FOR GAS BOOSTERS

Table 4 - Specifications - Gas Boosters

Model Name:		S20	S26
Boost Capacity:	(L/min)		
- L/min. @ 20°C rise		20	26
- L/min @ 25°C rise		16	24
Maximum Rated Flow:	(L/min)	20	26
Minimum Supply Pressure for Maximum rated flow: (1)	(kPa)	120	200
Minimum Flow for Operation:	(L/min)	2.4	2.4
Frost Protection:		Yes	Yes
Gas Consumption (Maximum / Minimum):	(MJ/hr.)	125 - 18	188 - 23
Star Rating (AS 4552 - 1998):		5.5	5.0
Hot Water Delivery Temperature: (2)		60°C	60°C
Dimensions: Height x Width x Depth:	(mm)	530 x 350 x 194	530 x 350 x 194
Weight:	(Kg)	15	21

(1) - Units will operate at lower pressures but the rated flow will not be achieved.

(2) - Gas boosters for Solar hot water applications should be preset to deliver a minimum temperature of 60°C.

Gas boosters factory pre set to 60°C or 65°C will be marked as such. If there are no temperature markings on the water heater, on site conversion is required. This is a simple procedure, contact your Service Agent.

INSTALLATION & MAINTENANCE - ALL SYSTEMS

REGULATIONS AND OCCUPATIONAL HEALTH AND SAFETY (OH&S)



Installation and commissioning must be performed by authorised persons. Solar systems must be installed in accordance with these instructions and all regulatory requirements which exist in your area including those in relation to manual lifting, working at heights and on roofs. Applicable publications and regulations may include:

- AS 5601 Gas Installations
- AS/NZS 3500 National Plumbing and Drainage
- AS/NZS 3000 Wiring rules
- Building Codes of Australia (BCA)
- Local Occupational Health and Safety (OH&S) regulations

This appliance is not suitable for use as a domestic spa pool or swimming pool heater.

Solar collectors are heavy and bulky items and are usually positioned on the roofs of buildings. Australian State and Territories have a principal Occupational Health and Safety (OH&S) Act which contains requirements relating to the handling of large, bulky or awkward items and the prevention of falls from elevated surfaces. Persons installing solar collectors must be aware of their responsibilities and be adequately trained and qualified, in accordance with local OH&S requirements.

LOCATION - GENERAL INFORMATION

All system components must be in an accessible location. The storage cylinder must be accessible without the use of a ladder or scaffold. Sufficient clearances shall allow access to, and removal of, all serviceable parts. Ensure the PTR valve, pump kit, drain lines and thermostat and elements for electric systems have sufficient clearances and are accessible for service and removal. The information on any data plates must also be readable. In the case of vitreous enamel lined cylinders, leave a clearance of the height of one storage cylinder above the cylinder being installed so the sacrificial anode can be inspected and replaced. This does not apply to stainless steel cylinders.

Select suitable areas of roof on which to install the solar collectors as close as practicable to the cylinder. Ensure that the area is even and without cracked or damaged tiles. Collectors should be positioned for optimum solar benefit. Refer to the section 'INSTALLATION OF SOLAR COLLECTORS' for more information.

The solar pump kit and gas booster heater require an AC 240V power supply. A weatherproof 240V, 10A earthed power point must therefore be provided adjacent to these. All electrically boosted solar hot water heating elements must be connected to an independent, fused, AC 240V 50 Hz power supply with an isolating switch installed at the switch board.

STORAGE CYLINDER LOCATION

The storage cylinder should be placed as close as practicable to the most frequently used hot water outlet point or points to minimise the delay time for hot water delivery. This will usually be the kitchen tap.

The solar storage cylinders have an ingress protection rating of IPX4 making them suitable for internal or external installation. Rinnai 'external' gas boosters are suitable for external installation only.

Storage cylinders must be installed in freestanding mode on a level and stable base. For external installations, storage cylinders should be mounted on a concrete base at least 50mm thick or on well seasoned, evenly spread hardwood slats with a thickness of at least 25mm. Where property damage can occur, storage cylinders should be installed with an approved safe tray (overflow tray).

Ensure the cylinder does not stand on wet surfaces.

INSTALLATION & MAINTENANCE - ALL SYSTEMS

GAS BOOSTER LOCATION AND MOUNTING (where applicable)

The gas booster is designed for 'Outdoor' Installation only. As such, it must be located in an above ground open air situation with natural ventilation, without stagnant areas, where gas leakage and products of combustion are rapidly dispersed by wind and natural convection.

WATER PIPES

All hot water pipework should be insulated with sealed Polyethylene foamed or equivalent insulation to optimise performance and energy efficiency. Such insulation may also be mandatory under local regulations. With the exception of solar collector flow and return pipes, water pipe sizing should be performed in accordance with AS/NZS 3500.



The collector flow and return pipes should be a minimum of 15 mm copper tube. Plastic pipe must not be used. Plastic pipe is not suited to the high water temperatures and pressures that may occur in the collector flow and return system.

The maximum recommended combined lengths of the solar cold and solar hot pipes are as follows:

Pipe Size	Number of Collectors		
	1-2	3	4
DN 15 (metres)	40	30	15
DN 20 (metres)	Not recommended	40	20

WATER SUPPLY

The minimum and maximum water pressures for the various systems are listed in **Table 2**. Approved pressure limiting valves may be required if the 'Maximum' rated water supply pressures are exceeded. For gas boosted systems to achieve the rated flow through the outlet of the continuous flow water heater, the minimum water supply pressures must be supplied. The systems will operate at lower pressures but the rated flow will not be achieved.

Water chemistry and impurity limits are detailed in the separate Warranty document. Most metropolitan water supplies fall within these requirements. If you are unsure about water quality, contact your water authority. If sludge or foreign matter is present in the water supply, a suitable filter should be incorporated in the water supply to the storage cylinder.

HOT WATER DELIVERY TEMPERATURE

Local regulations and/or the requirements of AS/NZS3500.4 must be considered regarding the temperature limitations of hot water supplied to areas used primarily for personal hygiene. The temperature of water to these areas is limited to 45°C for early childhood centres, primary and secondary schools and nursing homes or similar facilities for young, aged, sick or people with disabilities and 50°C for all other buildings. To comply with these requirements, a temperature limiting device, such as a thermostatic mixing or tempering valve, will be required on all solar hot water systems as detailed in **Figures 7 and 8**.

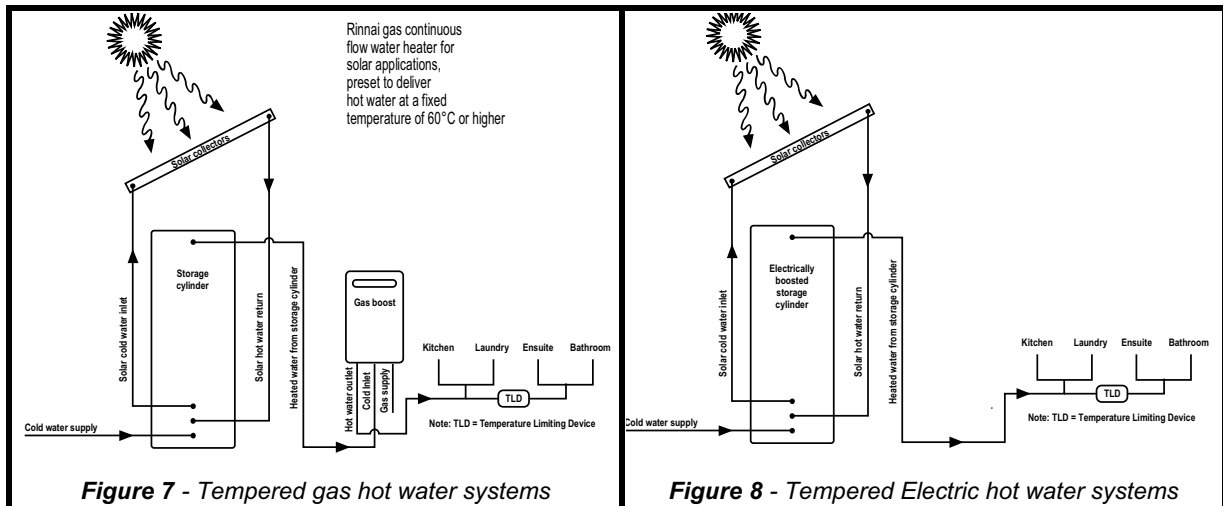

INSTALLATION & MAINTENANCE - ALL SYSTEMS

VALVES & FITTINGS

The following valves and fittings are supplied with your solar hot water system:

- A combined pressure and temperature (PTR) relief valve, capacity 10 kW. Relief valve pressure settings vary with models. This valve is fitted at the top of the storage cylinder. The PTR valve is a safety device and it is mandatory that it is fitted by the installer in all installations.
- A non return valve fitted on the solar pump outlet to prevent backflow through the pump from the solar collectors. This valve is factory connected.
- For gas boosted systems, elbow connections for the hot, cold and gas supply are fitted at the bottom of the gas booster.
- Fittings as shown in **Figures 27 - 30 and 34 - 36**.

The following valves & fittings are to be supplied by the installer:

- A cold water expansion control valve (ECV). An ECV must be fitted in Western Australia and South Australia to the cold water supply to the storage cylinder to comply with local regulations. An ECV is recommended in all other geographical areas where the water supply has a tendency to cause scaling. This will reduce hot water discharge from the Pressure and Temperature Relief (PTR) valve which minimises wear on this valve.
- A stop cock, non return valve and line strainer. Combination valves incorporating two or more of these functions (such as 'Trio' valves) are suitable. These are fitted to the cold water supply to the storage cylinder by the installer.
- Cold water supply and hot water discharge pipework to and from the storage cylinder.
- Solar collector flow and return pipes and storage cylinder connections.
- An isolating valve and connection union for the gas supply to the gas booster.
- A approved pressure limiting valve (supplied with some systems) is required if the maximum rated water supply pressure in **Table 2** is exceeded.

INSTALLATION OF SOLAR COLLECTORS

REGULATIONS AND OCCUPATIONAL HEALTH AND SAFETY (OH&S)

Installation and commissioning must be performed by authorised persons. Rinnai solar systems must be installed in accordance with these Instructions and all regulatory requirements which exist in your area including those in relation to manual lifting, working at heights and on roofs. Applicable publications and regulations may include:

- AS 5601 Gas Installations
- AS/NZS 3500 National Plumbing and Drainage
- AS/NZS 3000 Wiring rules
- Building Codes of Australia
- Local Occupational Health and Safety (OH&S) regulations



- **Solar collectors are heavy and bulky items and are usually positioned on the roofs of buildings. Each Australian State and Territory has a principal Occupational Health and Safety (OH&S) Act which contains requirements relating to the handling of large, bulky or awkward items and the prevention of falls from elevated surfaces. Persons installing solar collectors must be aware of their responsibilities and be adequately trained and qualified, in accordance with local OH&S requirements.**

SYSTEM ORIENTATION AND INCLINATION

The performance of any solar hot water system is determined by the way that the system is installed.

In Australia, the solar collectors should face the equator (North) as shown below. Where this orientation is not practical, collectors facing within 45 degrees from North (between North-East and North-West) area acceptable, with a reduction in efficiency of approximately 5%. If the bulk of hot water consumption occurs before 2 pm face the collectors in a North - Easterly direction. If the bulk of hot water consumption occurs after 2 pm face the collectors in a North Westerly direction.

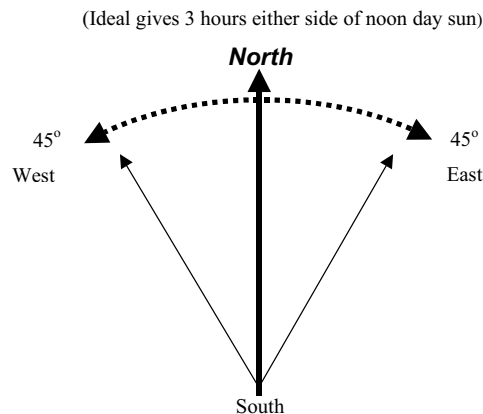

Figure 9 - Orientation angle of Collectors

The inclination of the solar collectors should ideally be the same as the latitude angle of the site. Inclinations within 20 degrees of the latitude angle of the site are acceptable, with a reduction in efficiency of approximately 5%.

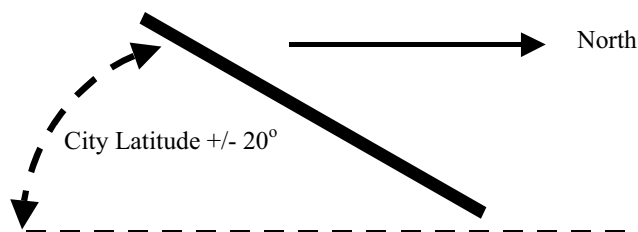

Figure 10 - Inclination of Collector

INSTALLATION OF SOLAR COLLECTORS

Table 6: Latitudes of Australian Cities

City	Latitude	City	Latitude	City	Latitude	City	Latitude
Adelaide	35°S	Cairns	17°S	Hobart	42°S	Port Hedland	20°S
Alice Springs	24°S	Canberra	35°S	Mildura	34°S	Rockhampton	24°S
Brisbane	27°S	Darwin	12°S	Melbourne	38°S	Sydney	34°S
Broken Hill	31°S	Geraldton	28°S	Perth	32°S	Townsville	19°S

For all installations the collector bank must slope upwards approximately 8 mm per collector from inlet to outlet as shown below:

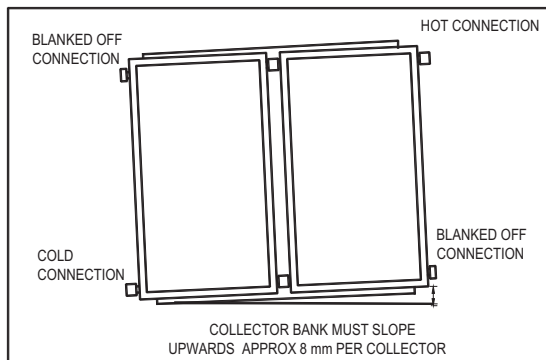

Figure 11 - Enduro, Equinox, Excelsior Collectors

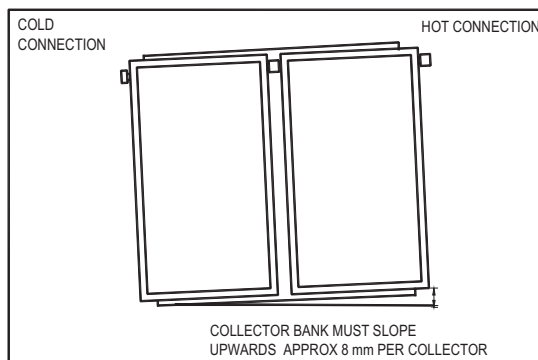

Figure 12 - E-Frost Collectors

A maximum of three collectors can be connected together in parallel. Inlet (Cold) and outlet (Hot) connections are made at opposite corners of the collector array.

SOLAR COLLECTOR ROOF MOUNTING OPTIONS

For mounting options not shown in **Figure 13**, for example in areas where the cyclone frame cannot not be used, consult your nearest Rinnai Branch or Rinnai Representative.

It is normal to mount the solar collectors down close to the gutter. Roof construction must be checked to ensure that the roof timbers are capable of supporting the additional load. (Refer to AS3500.4 Appendix H).

For tiled roof installations. Check for cracked or damaged tiles in the area of proposed installation. Replace any faulty tiles.

If spare tiles are not available, swap damaged tiles with good ones from along the gutter line.

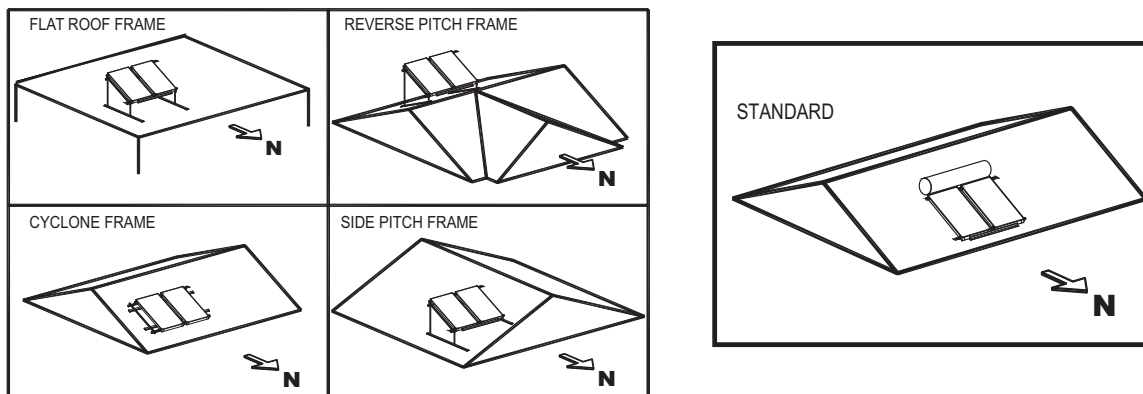

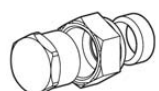



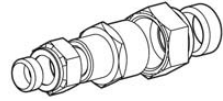



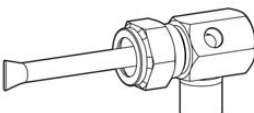
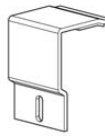





Figure 13 - Solar Collector Roof Mounting Options

INSTALLATION OF SOLAR COLLECTORS

SOLAR COLLECTOR INSTALLATION COMPONENTS

Table 7 - Components for installing Collectors

COLLECTOR MOUNTING COMPONENTS (supplied in Collector Installation kit)				COLLECTOR CONNECTING COMPONENTS (supplied in Collector Installation kit)			
Number of Collectors				Number of Collectors			
1	2	3		1	2	3	
2	-	-	 Mounting Rail Small 14201196	2	2	2	 Stop End (1 x plug 3/4G (Kinco) + 1 x 3/4 Kinco nut and olive) (Not used with E-Frost Collector) 28801025
-	2	-	 Mounting Rail Medium 14201197	-	-	2	 Compression Union 3/4 - 3/4 (1 x Nipple G3/4 (Kinco) + 2 x 3/4 Kinco nut and olive) (Half of these not used with E-Frost Collector) 32201709
-	-	2	 Mounting Rail Large 14201198	-	2	4	 Compression Union 3/4 - 1/2 (1 x Nipple G3/4 (Kinco) + 1 x 3/4 Kinco nut and olive + 1 x 1/2 Kinco nut and olive) 33201711
2* + 2#	4*	6*	 Collector Mounting Strap * supplied with collectors, # supplied in collector installation kit 12401012	1	1	1	 Air Bleed Valve 11007701
4	4	4	 M8 Bolt, Washer and Nut (used to bolt collector mounting strap to mounting rail) BOLT 22601052 WASHER 17401072 NUT 16801062	1	1	1	 Hot Sensor Sheath 10204714
4	8	1 2	 Collector Retainer 26601706	1	1	1	 Hot Sensor Lead (20 m) 31002706
4	8	12	 M6 Bolt, Washer and Nut (used with collector retainers) BOLT 22601073 WASHER 17401073 NUT 16801007	1	1	1	 Kinco Nut 1/2 16801012
INSTALLATION KITS PART NUMBERS 1 collector : R33202739 2 collectors : R33202740 3 collectors : R33202741				1	1	1	 Kinco Olive 1/2 33001012

INSTALLATION OF SOLAR COLLECTORS

STANDARD INSTALLATION

Collector Mounting Component Pre Assembly for a Standard Installation

- Assemble the collector rail components as shown in **Figure 14** below.
- Only loosely attach the collector retainers to the rails.

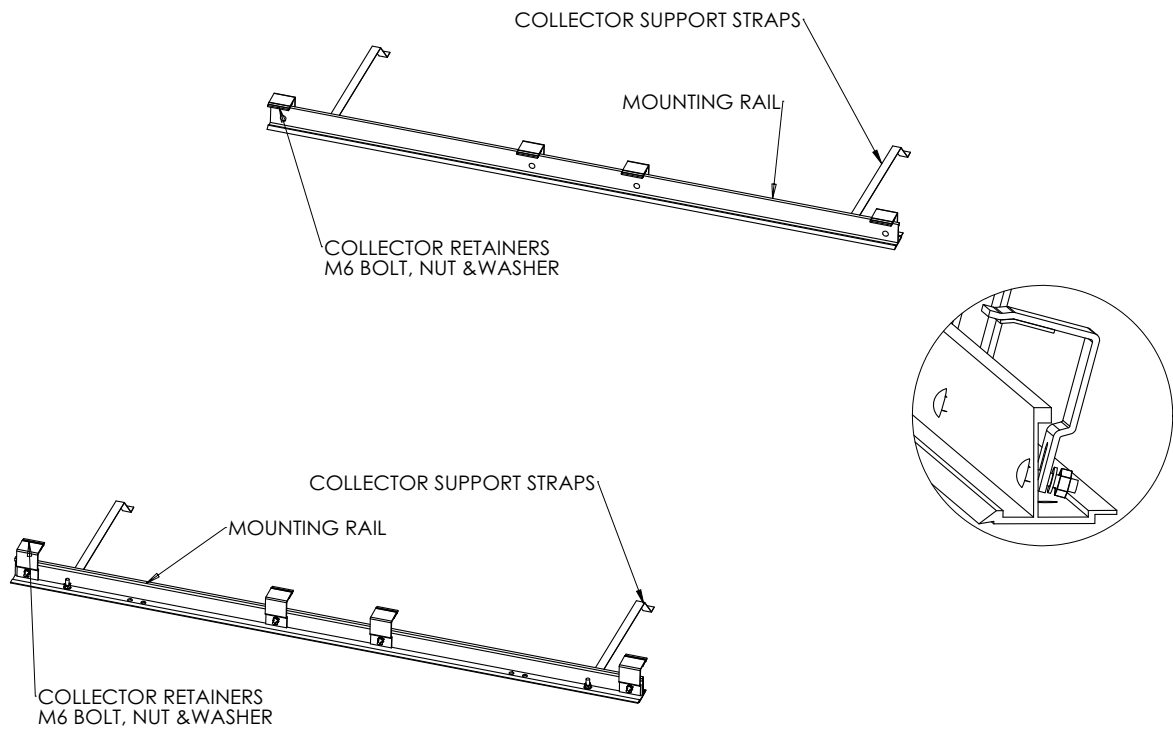

Figure 14 - Collector Mounting Components



This installation is not suitable for use in cyclonic areas. For further details, please contact your local Rinnai Solar distributor.

INSTALLATION OF SOLAR COLLECTORS

STANDARD INSTALLATION CONTINUED

Fastening (Collectors to a Metal Roof)



This installation is not suitable for in cyclonic areas. For further details, please contact your local Rinnai Solar distributor.

- Position the lower collector mounting rail assembly so that the rail is angled to ensure the collectors have an 8 mm / collector rise.
- For aesthetic reasons it is best to mount as close as possible to the gutter.
- Attach the collector mounting straps to the rafter or truss under the tiles as shown in **Figure 15**.

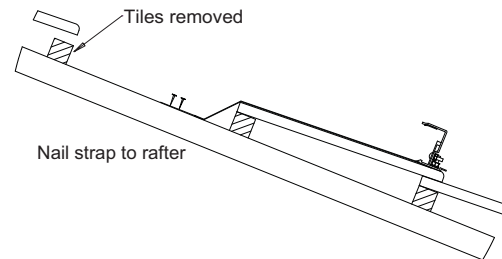

Figure 15 - Mount Lower Collector Rail

- Place the collector(s) onto the roof above the lower rail. If more than one collector is being installed then join them together using the compression fittings supplied.
- Push down on the collector retainers to clamp the collector and tighten the nuts as shown in **Figure 16**.

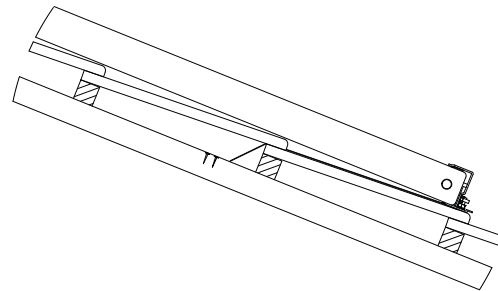

Figure 16 - Mount collector on Roof

- Position the upper collector rail above the collectors. Push down on the retainers to clamp the collector and tighten the nuts.
- Attach the collector mounting straps to the rafter or truss under the tiles as shown in **Figure 17**.

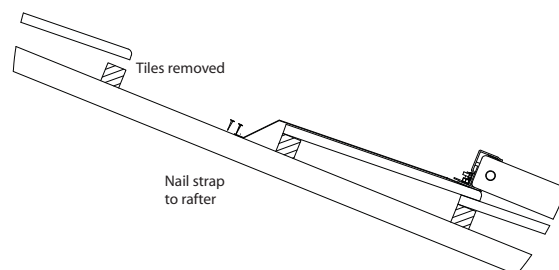

Figure 17 - Attach Mounting Straps

- Replace the tiles and ensure the collector is secure as shown in **Figure 18**.

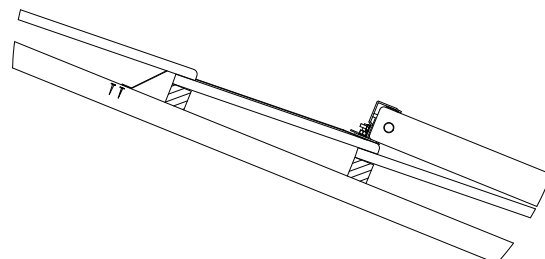

Figure 18 - Replace Tiles

INSTALLATION OF SOLAR COLLECTORS

STANDARD INSTALLATION CONTINUED

Fastening (Collectors to a Tiled Roof)



This installation is not suitable for use in cyclonic areas. For further details, please contact your local Rinnai Solar distributor.

- Position the lower collector mounting rail assembly so that the rail is over the roof purlin and the rail is angled ensure the collectors have an 8 mm / collector rise. For aesthetic reason it is best to mount as close as possible to the gutter.
- Drill through the roof iron and purlin using the holes in the rail as a guide. Apply some silicone sealant down the holes to ensure no water leakage.
- Bolt the rail to the roof purlin using a suitable fastener as shown in **Figure 19**.

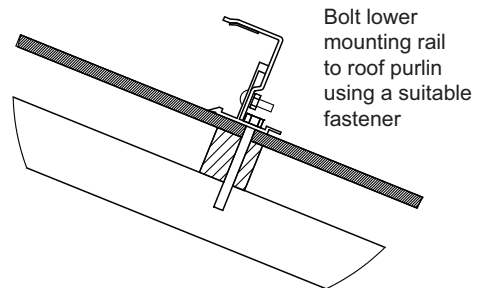

Figure 19 - Mount Lower Collector Rail

- Position the collector(s) onto the roof above the lower rail. If more than one collector is being installed, join them together using the compression fittings supplied.
- Push down on the collector retainers to clamp the collector and tighten the nuts.
- Place the upper collector mounting rail above the collectors. Push down on the collector retainers to clamp the collector and tighten the nuts.
- Drill through the roof iron and purlin using the upper mounting rail as a guide. Apply some silicone sealant down the holes to ensure no water leakage and secure with suitable fasteners as shown in **Figure 20**. Alternatively the rail can be attached to the roof using the collector mounting straps.

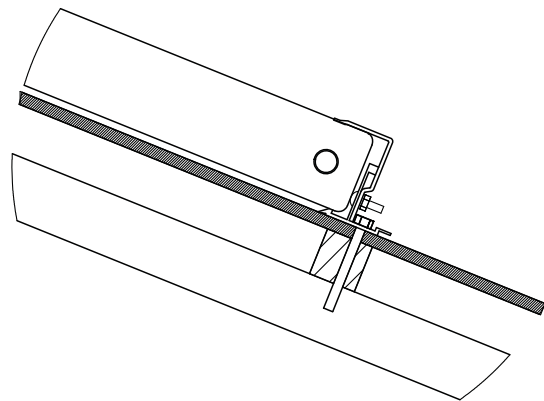

Figure 20 - Mount Collector on Roof

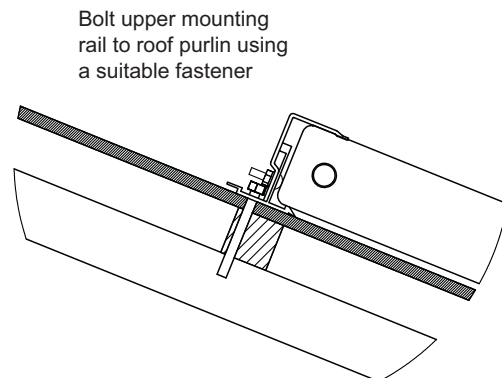

Figure 21 - Attach Upper Rail

INSTALLATION OF SOLAR COLLECTORS



This installation is not suitable for use in cyclonic areas. For the correct frame for use in cyclone areas, contact your local Rinnai Solar distributor.

FRAMED INSTALLATIONS - FLAT ROOF FRAMES

Table 7 - Framed Installations

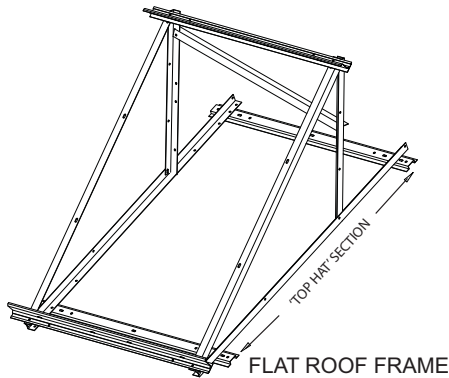

- Assemble the flat roof frame as shown in the diagram supplied with the flat roof frame kit using the bolts, nuts and washers supplied.
- Position the frame on the roof ensuring that the 'top hat' sections are on suitable load bearing surfaces, and that the collectors have the required 8 mm per metre rise.
- Secure the frame to the roof in accordance with local building authority requirements using suitable fastening system.
- Attach the cylinder cradle and collector mounting rails to the frame. Loosely attach the collector retainer brackets to the collector mounting rails.
- Place the collector on the frame between the rails. If more than one collector is being installed join them together using the compression fittings supplied. Press down on the collector retainer to clamp the collector and tighten the nuts.

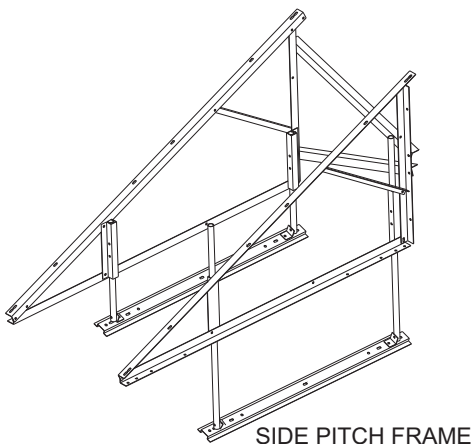
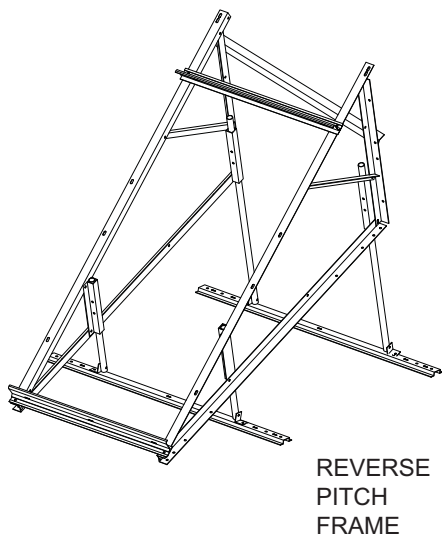

- Both the Reverse and Side Pitch Frames comprise of a flat roof frame kit and an additional kit with leg components.
- Assemble the flat roof frame with the exclusion of the top hat sections using the bolts, nuts and washers supplied.
- Attach the leg sockets to the trusses.
- Fit the long and short legs into the sockets and attach the pivot brackets to the ends. Use the long and short legs in the correct sockets depending on whether a Reverse Frame or a Side Pitch Frame is required.
- Fasten the pivot brackets to the top hat sections.
- Position the frame on the roof ensuring the cylinder and collector load will be adequately supported.
- Adjust the frame to the approximately the correct level. Temporarily clamp in place.
- If necessary, cut the excess from the legs so that they will not protrude into the area where the collector will be mounted.
- Secure the frame to the roof in accordance with local building authority requirements using a suitable fastening system.
- Once the frame is fully fastened to the roof, use a spirit level to adjust the frame height on the legs ensuring that the collectors have the required 8mm per metre rise.
- Drill the legs through one of the holes in the leg sockets and secure with the nuts and bolts supplied.
- Attach the collector mounting rails to the frame. Loosely attach the collector retainer brackets to the collector mounting rails.
- Place the collector on the frame between the rails. If more than one collector is being installed join them together using the compression fittings supplied. Press down on the collector retainer to clamp the collector and tighten the nuts.

INSTALLATION OF SOLAR COLLECTORS

FRAMED INSTALLATIONS - CYCLONE FRAME

Assemble cyclone frame and mount collectors as described in instructions provided with cyclone frame kit.

COMMERCIAL INSTALLATIONS

Commercial system comprise of multiple of 2-3 collectors joined together. **Figure 22** shows the roof spacing required for the collector sets.

Figures 23 and 24 shows the flow and return piping layout for multiple collector sets.



NOTE That the combined length of flow and return piping for each collector set is approximately the same. This will result in even flow to all collectors and optimum performance.

Pipe sizing shown in table below:

Table 8 - Commercial Pipe Sizing

PIPE AND PUMP SIZING CHART - COMMERCIAL ARRAYS											
Total collectors in array	Up to	10	20	30	40	50	60	70	80	90	100
Pipe sizing for solar flow and return manifolds		DN20	DN20	DN25	DN32	DN32	DN32	DN40	DN40	DN40	DN50
Pump		20-60N	20-60N	20-60N	25-80N	25-80N	25-80N	25-80N	25-80N	25-80N	25-80N
	Maximum pipe run in collector circuit (m)										
Pump speed	1	30	-	-							
	2	60	40	20							
	3	100	100	100	100	100	100	100	100	100	100

INSTALLATION OF SOLAR COLLECTORS

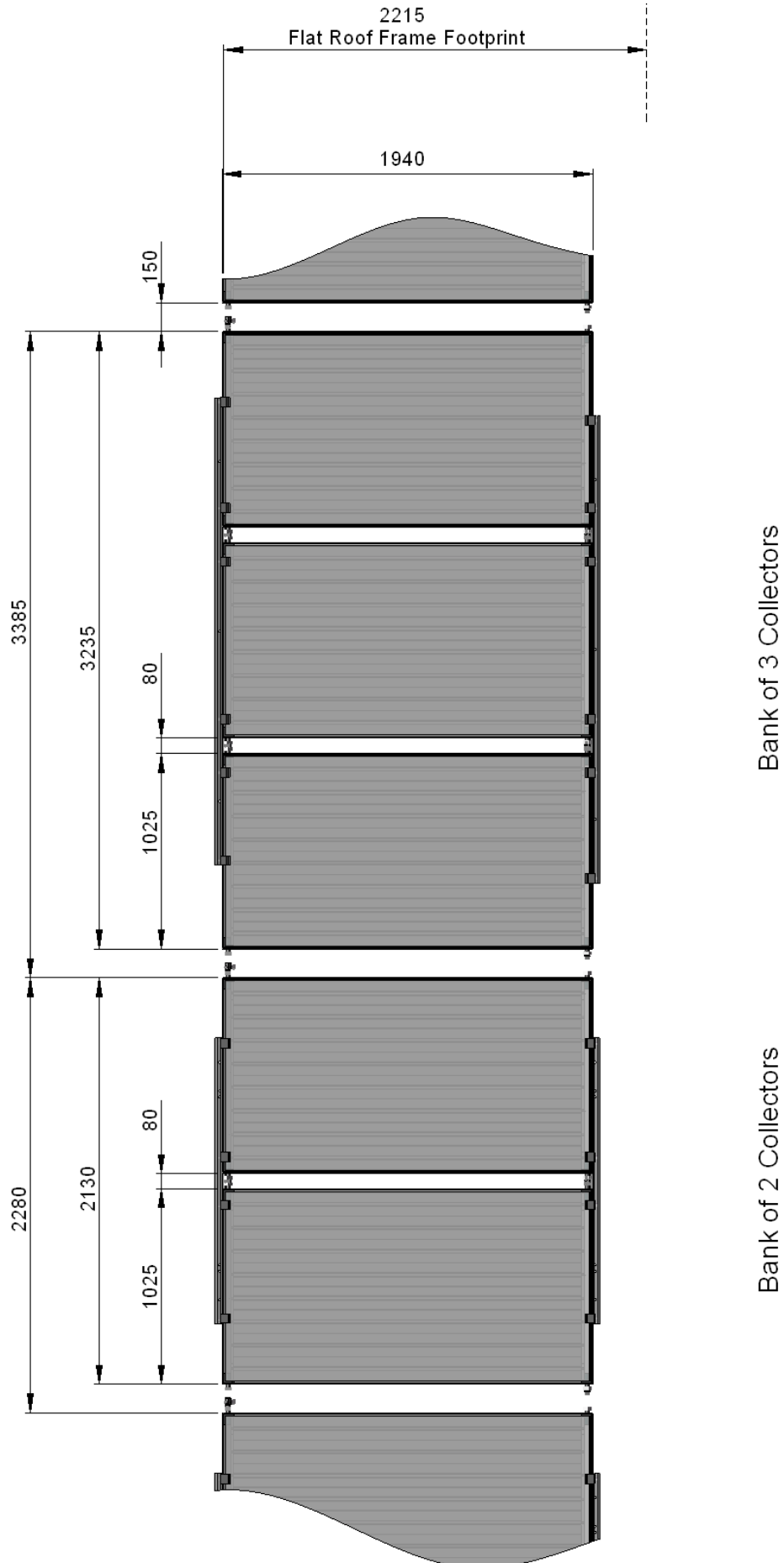

Figure 22 - Commercial Collector Installation

INSTALLATION OF SOLAR COLLECTORS

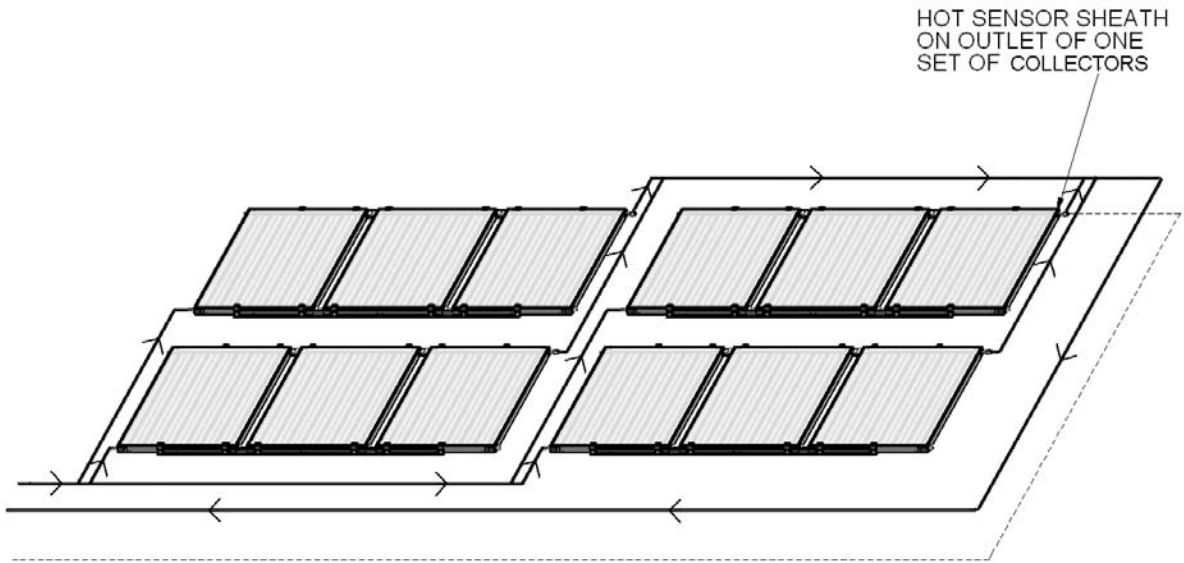

Figure 23 - Flow and Return Lines for Commercial Systems

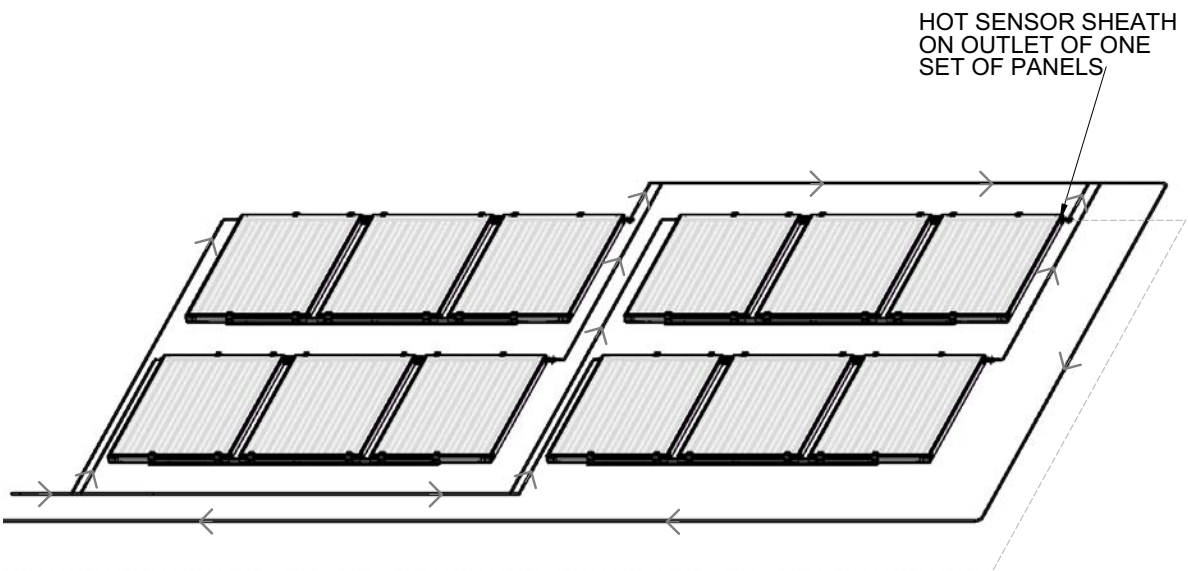

Figure 24 - E-Frost Collectors

INSTALLATION OF SOLAR COLLECTORS

COLLECTOR FITTINGS INSTALLATIONS

Connect the fittings to the collectors as shown in the diagrams below:

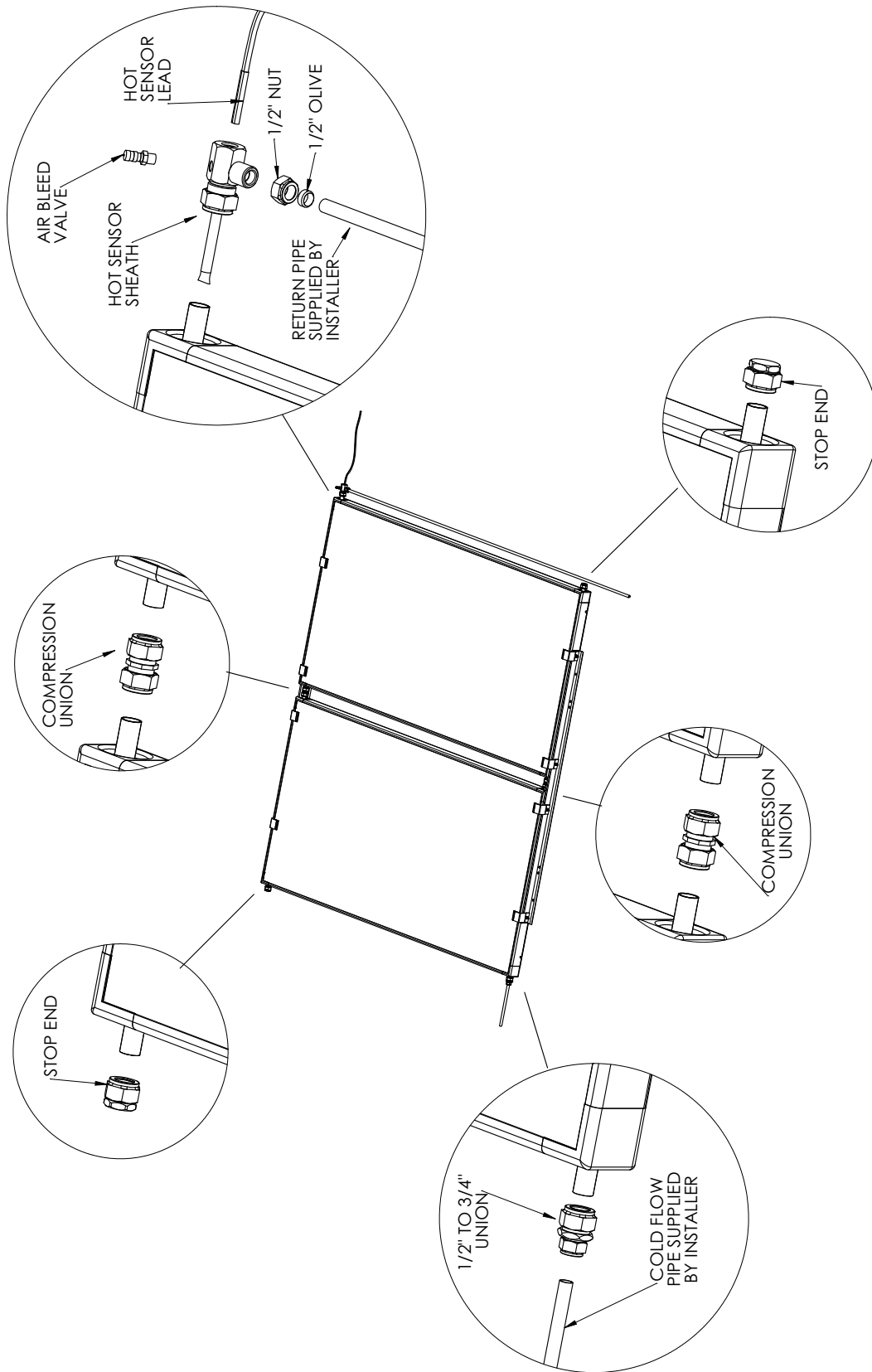
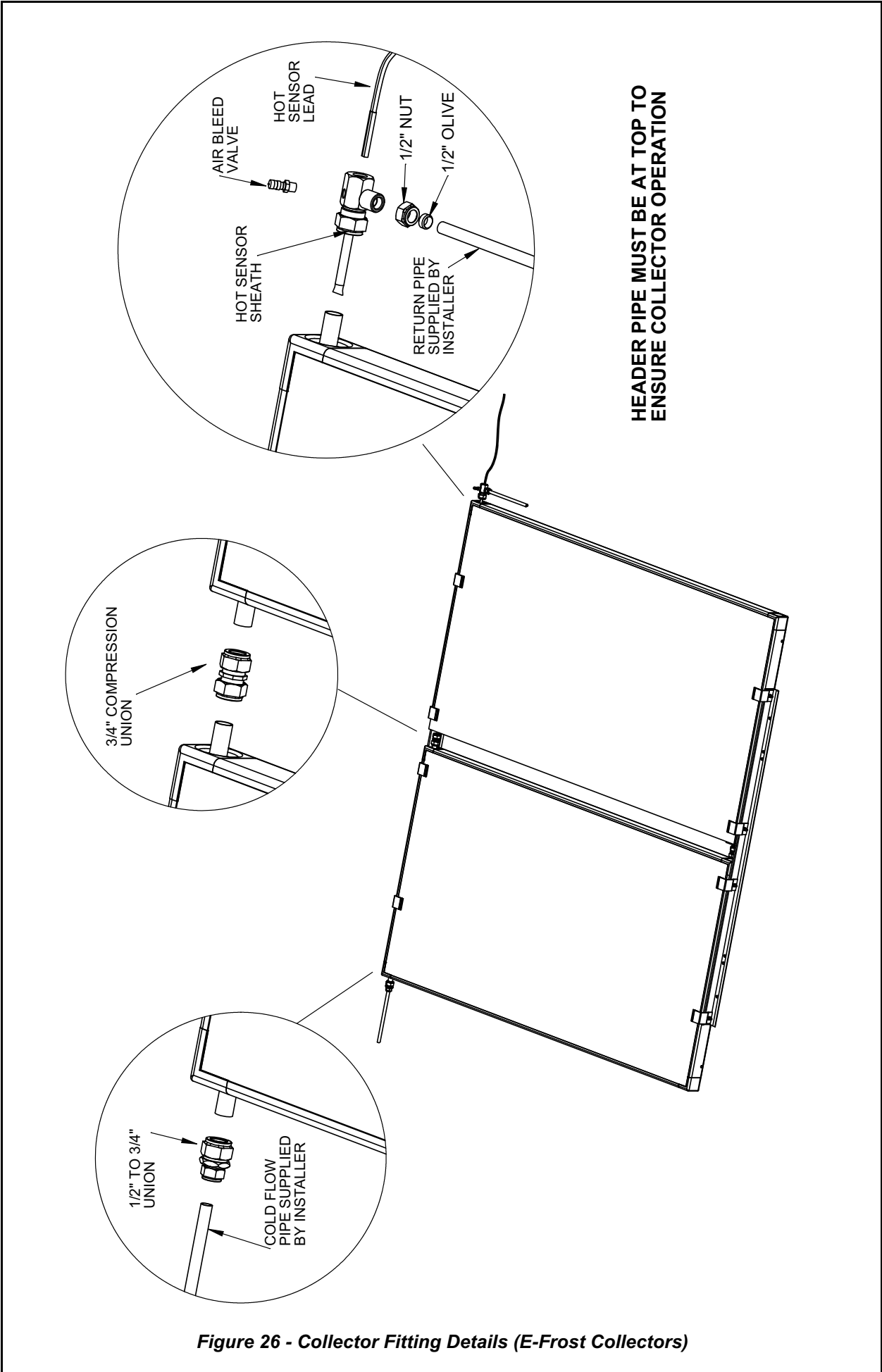

Figure 25 - Collector Fitting Details (Enduro, Equinox and Excelsior Collectors)

INSTALLATION OF SOLAR E-FROST COLLECTORS



INSTALLATION & MAINTENANCE - GAS BOOSTED

OVERVIEW OF SYSTEM COMPONENTS

The range of gas boosted solar hot water systems include all the components shown in **Figure 27 - 30** (refer to the appropriate Figure depending on cylinder type/size and kit on the following pages).

The pump kit and associated plumbing connections are factory pre-assembled. All other components and fittings will require connection on site. The gas booster and pump/controller kit may be mounted to the front of the storage cylinder casing or in an alternative external location. In all cases the heated outlet of the cylinder is connected to the cold water inlet of the gas booster.

GAS BOOSTER LOCATION

The gas booster is designed for 'Outdoor' Installation only. As such, it must be located in an above ground open air situation with natural ventilation, without stagnant areas, where gas leakage and products of combustion are rapidly dispersed by wind and natural convection. The location must comply with the clearances specified in AS5601.

The gas booster must be mounted on a vertical structure with the water and gas connections on the underside pointing downwards. In most installations the gas booster is mounted directly on the storage cylinder using two custom made mounting brackets. In all cases the heated outlet of the cylinder is connected to cold water inlet of the gas booster.

GAS SUPPLY

The maximum gas consumption of the gas booster and the required gas pressure are shown on the appliance data plate. If the gas pipe sizing is insufficient the customer will not get the full performance benefit. Gas pipe sizing must consider the gas input to the gas booster as well as all the other gas appliances on the premises. The gas meter and regulator must be specified for this gas rate. An approved sizing chart such as the one in AS5601 should be used. An approved full flow isolation valve and disconnection union must be fitted to the gas supply inlet of the gas booster. Isolation valves must not be fitted directly.

HOT WATER DELIVERY TEMPERATURE

Gas boosters for use in solar hot water systems are preset to deliver a fixed temperature of 60°C in accordance with plumbing regulations. In addition, they contain the warning stating "Rinnai Water Controllers are NOT compatible with solar hot water installations and MUST NOT BE USED" in the vicinity of the temperature controller connections inside the appliance.



Gas Boosters other than models designated "S20", "S26" or "Solar" must not be used.

Gas Boosters marked with the text: "THIS APPLIANCE DELIVERS WATER NOT EXCEEDING 50°C IN ACCORDANCE WITH AS 3498" are incompatible with solar hot water systems and must not be used.

INSTALLATION & MAINTENANCE - GAS BOOSTED SYSTEMS

CLEARANCES

Figure 5.3 is reproduced below. Note that AS 5601-2004 was current at time of printing but may have been superseded. It is the installer's responsibility to ensure current requirements are met.

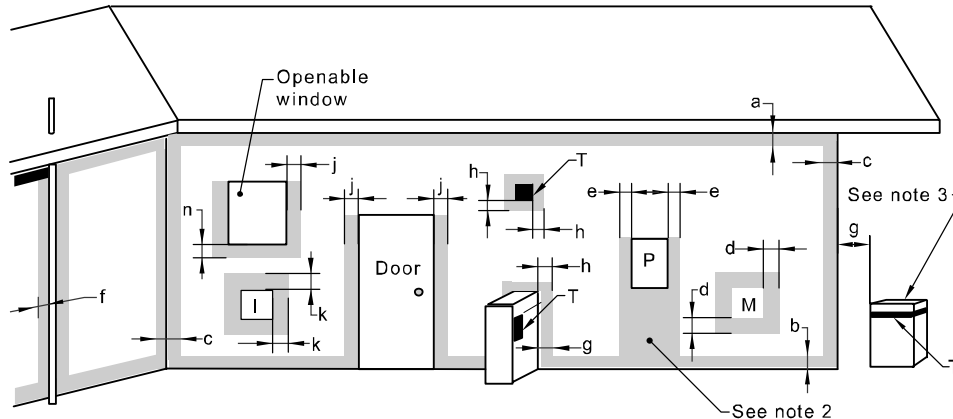

LEGEND:

T = Flue terminal
 I = Mechanical air inlet
 M = Gas meter
 P = Electricity meter or fuse box
 Shading indicates prohibited areas for flue terminals

Ref.	Item	Minimum clearances (mm)	
		Natural draft	Fan assisted
a	Below eaves, balconies and other projections:		
	• Appliances up to 50 MJ/h input	300	200
	• Appliances over 50 MJ/h input	500	300
b	From the ground, above a balcony or other surface †	300	300
c	From a return wall or external corner †	500	300
d	From a gas meter (M) (see 4.7.11 for vent terminal location of regulator)	1000	1000
e	From an electricity meter or fuse box (P)	500	500
f	From a drain pipe or soil pipe	150	75
g	Horizontally from any building structure † or obstruction facing a terminal	500	500
h	From any other flue terminal, cowl, or combustion air intake †	500	300
j	Horizontally from an openable window, door, non-mechanical air inlet, or any other opening into a building with the exception of sub-floor ventilation:		
	• Appliances up to 150 MJ/h input	500	300
	• Appliances over 150 MJ/h input up to 200 MJ/h input	1500	300
	• Appliances over 200 MJ/h input up to 250 MJ/h input †	1500	500
	• Appliances over 250 MJ/h input †	1500	1500
	• All fan-assisted flue appliances, in the direction of discharge	-	1500
k	From a mechanical air inlet, including a spa blower	1500	1000
n	Vertically below an openable window, non-mechanical air inlet, or any other opening into a building with the exception of sub-floor ventilation:		
	• Space heaters up to 50 MJ/h input	150	150
	• Other appliances up to 50 MJ/h input	500	500
	• Appliances over 50 MJ/h input and up to 150 MJ/h input	1000	1000
	• Appliances over 150 MJ/h input	1500	1500

† Unless appliance is certified for closer installation

All distances are measured to the nearest part of the terminal.

Prohibited area below electricity meter or fuse box extends to ground level.

See Clause 5.13.6.6 for restrictions on a flue terminal under a covered area.

See Appendix J, Figures J2(a) and J3(a), for clearances required from a flue terminal to an LP Gas cylinder. A flue terminal is considered to be a source of ignition.

For appliances not addressed above acceptance should be obtained from the technical regulator

FIGURE 5.3 (in part) MINIMUM CLEARANCES REQUIRED FOR BALANCED FLUE TERMINALS, FAN-ASSISTED FLUE TERMINALS, ROOM-SEALED APPLIANCE TERMINALS OR THE TERMINALS OF OUTDOOR APPLIANCES

AS 5601 - Figure 5.3 'Clearances' - Gas Booster Flue Terminal

INSTALLATION & MAINTENANCE - GAS BOOSTED SYSTEMS

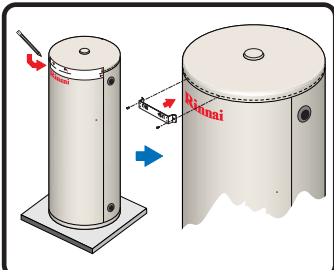
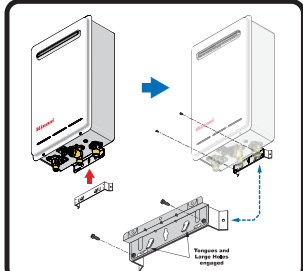
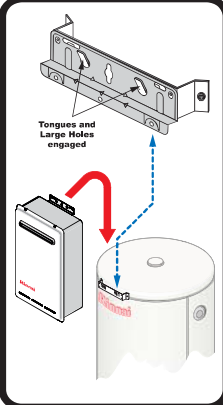
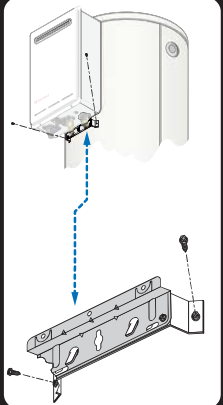
GAS BOOSTER MOUNTING	Sunmaster
<p>Step 1. Mount upper mounting bracket using template provided. (SG175 - SG215 are factory mounted)</p>	
<p>Step 2. Fix lower mounting bracket to Booster using screws provided.</p>	
<p>Step 3. Hang booster on bracket and secure with screws provided.</p>	
<p>Step 4. Secure lower mounting bracket to cylinder using screws provided.</p>	

If the gas booster is not mounted on the storage cylinder, ensure that the wall or structure on which it is to be mounted are capable of supporting the weight of the appliance and associated pipe work. Refer to **Table 4** for individual gas booster weights. For gas boosters installed on elevated structures or under floors specific requirements apply, refer to AS5601 for details. Location of gas booster flue terminal must be in accordance with Figure 5.3 of AS5601.

Sunmaster - SG175 or SG215 with SGPKIT

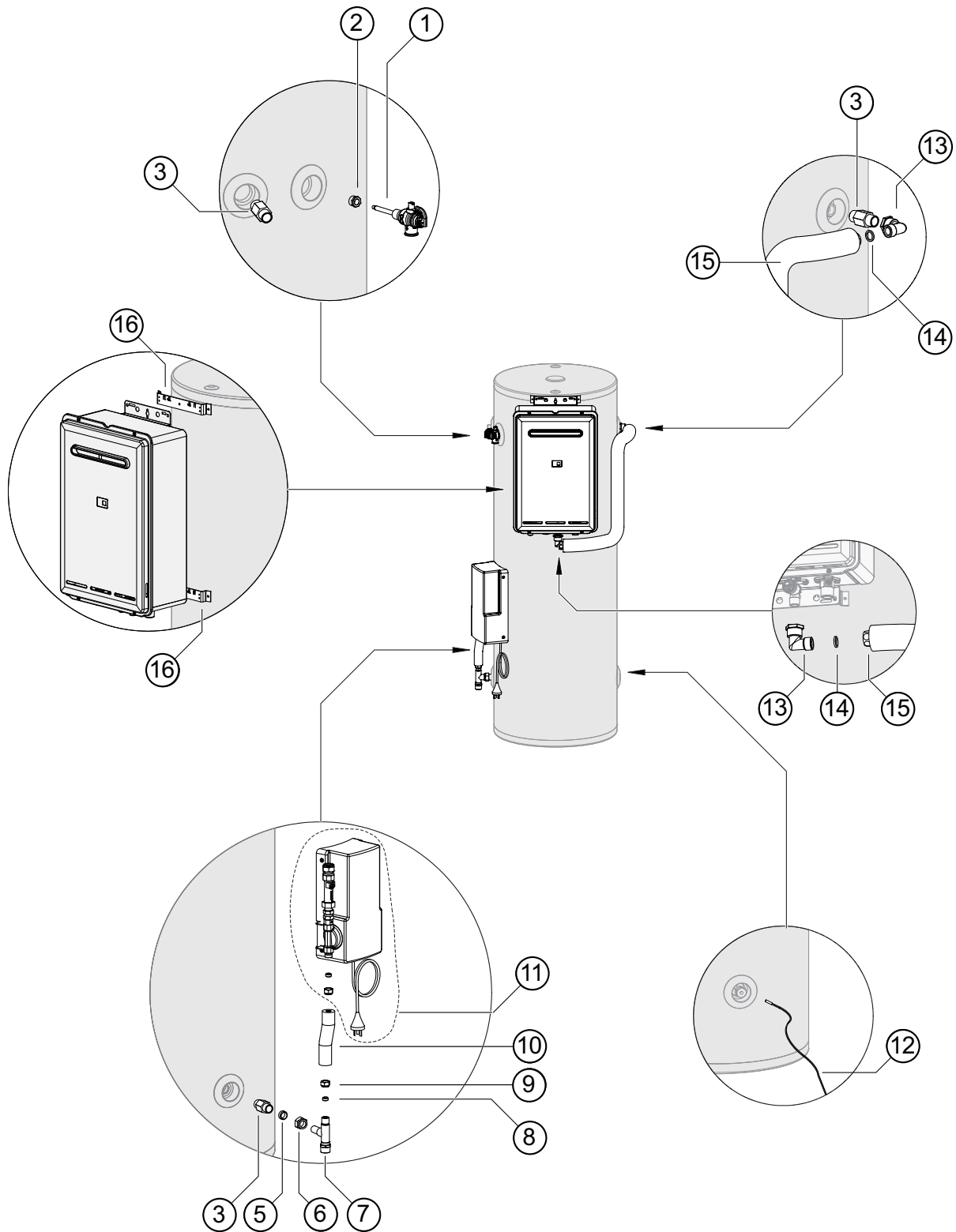
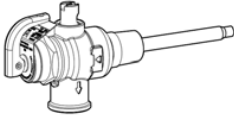

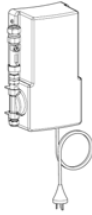
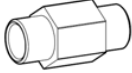
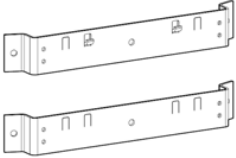







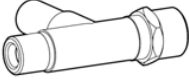





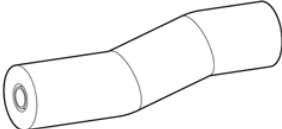
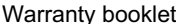

Figure 27 - Sunmaster Gas SG175 or SG215 with SGPKIT

INSTALLATION & MAINTENANCE - GAS BOOSTED SYSTEMS

Sunmaster SG175 or SG215 with SGPKIT

Items Supplied with Cylinder			Items Supplied in SGPKIT (cont...)		
①	1	 PTR Valve			
②	1	 Adaptor R $\frac{3}{4}$ x Rp $\frac{1}{2}$	⑪	1	 Pump and Controller Assembly (includes 2 x $\frac{1}{2}$ Kinco nut and olive, flow control valve and non return valve) Temperature sensor lead (31002710) included with assembly, but shown separately as item 12 for clarity 39001735
③	3	 Nipple R $\frac{3}{4}$			
⑬	2	 Gas Booster Mounting Brackets 1 x tabs bent 26601098 1 x tabs unbent 26601096	⑫	1	 Temperature Sensor with 2 m lead Part of Pump and Controller Assembly (39001735), but shown separately for clarity 31002710
			⑬	2	 Elbow $\frac{3}{4}$ Rp x $\frac{3}{4}$ G flexi 21201012
Items Supplied in SGPKIT			⑭	2	 Fibre Washer $\frac{3}{4}$ 17401008
⑤	1	 $\frac{3}{4}$ Kinco Olive 33001011	⑮	1	 Insulated Flexi Pipe 890 mm 11601070
⑥	1	 $\frac{3}{4}$ Kinco Nut 16801018	-	12	 Screws 22601048
⑦	1	 Copper Tee 11603936	-	3	 Cable Ties 39601036
⑧	2	 $\frac{1}{2}$ Kinco Olive 33001012 (*1 not needed)	*	2	 Nipples 17201003
⑨	2	 $\frac{1}{2}$ Kinco Nut 16801012 (*1 not needed)	-	1	 Saddle Clamp 27201015
⑩	1	 Insulated Copper Extension Pipe 11603348	-	1	 Warranty booklet 15401024
-	1	Operation and Installation Manual 15401030	-	1	RECS form 15401023
-	1	Booster and Pump Mounting Instruction Sheet 15401031	-	1	Standardsmark Sticker 15802091

*This kit is used for a variety of installations. Items marked with an * are not needed for this particular installation

Sunmaster - SG175 or SG215 with SGPKIT2

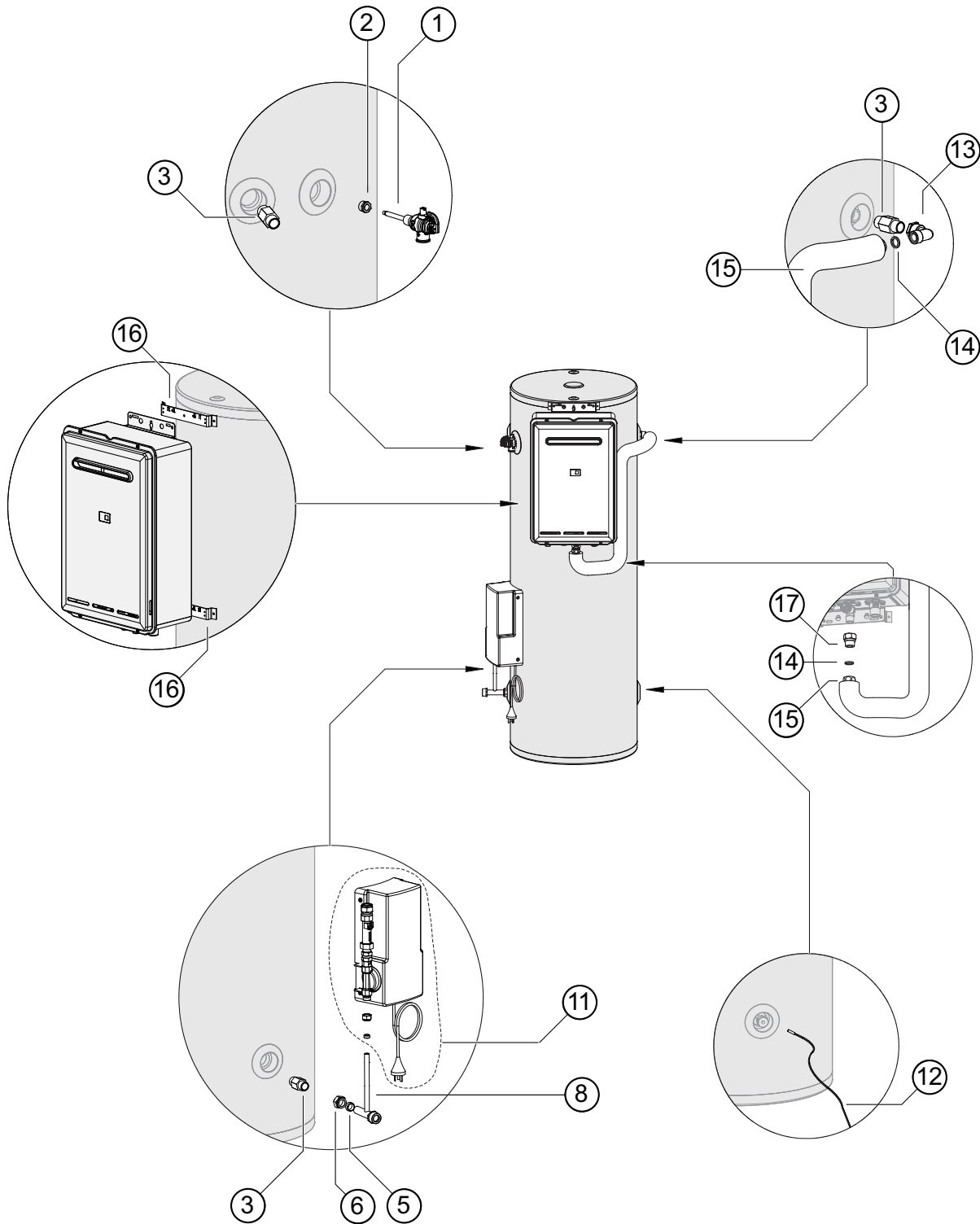
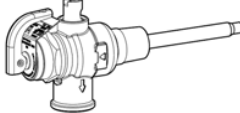



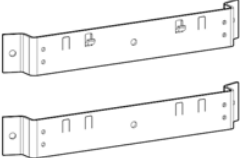





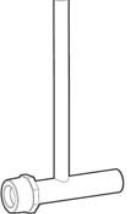



Figure 28 - Sunmaster Gas SG175 or SG215 with SGPKIT2

INSTALLATION & MAINTENANCE - GAS BOOSTED SYSTEMS

Sunmaster SG175 or SG215 with SGPKIT2

Items Supplied with Cylinder			Items Supplied in SGPKIT2 (cont...)					
①	1	 PTR Valve	⑪	1	 Pump and Controller Assembly (includes 2 x ½ Kinco nut and olive, flow control valve and non return valve) Temperature sensor lead (31002710) included with assembly, but shown separately as item 12 for clarity 39001735			
②	1	 Adaptor R ¾ x Rp ½	⑫	1	 Temperature Sensor with 2 m lead Part of Pump and Controller Assembly (39001735), but shown separately for clarity 31002710			
③	3	 Nipple R ¾						
⑯	2	 Gas Booster Mounting Brackets 1 x tabs bent 26601098 1 x tabs unbent 26601096	⑬	1	 Elbow ¾ Rp x ¾ G flexi 21201012			
			⑭	2	 Fibre Washer ¾ 17401008			
Items Supplied in SGPKIT2			⑮	1	 Insulated Flexi Pipe 890 mm 11601070			
⑤	1	 ¾ Kinco Olive 33001011						
⑥	1	 ¾ Kinco Nut 16801018						
⑧	1	 Cold Inlet Copper T 11603921				-	10	 Screws 22601048
						-	1	Operation and Installation Manual 15401021
			-	1	Warranty booklet 15401024			
			-	1	RECS form 15401023			

Sunmaster SG270 - SG340 with SGPKIT 270

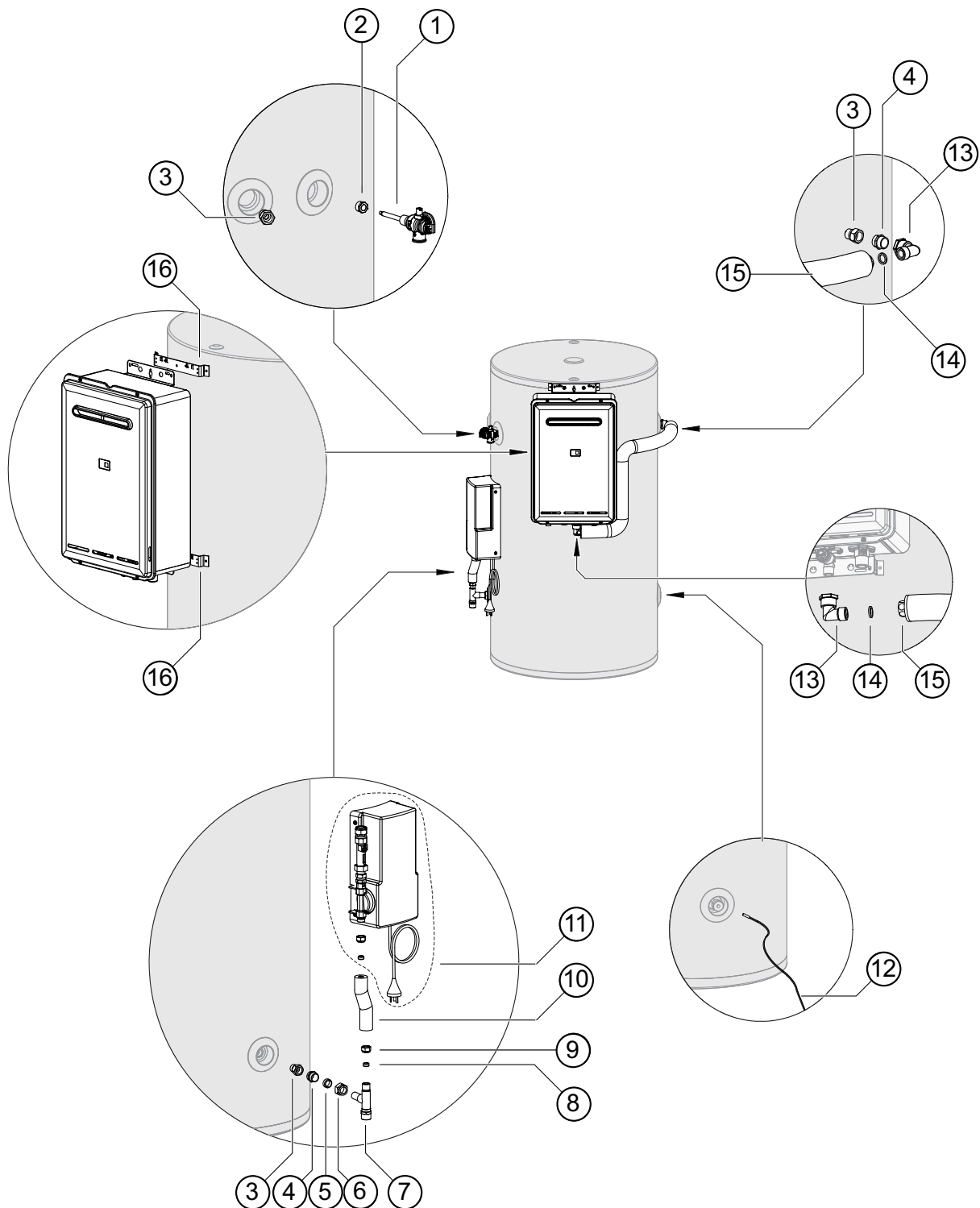
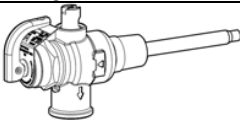









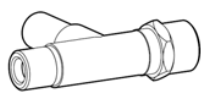



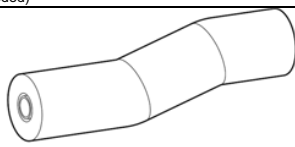
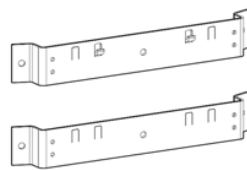





Figure 29 - Sunmaster Gas SG270 or SG340 with SGPKIT270

INSTALLATION & MAINTENANCE - GAS BOOSTED SYSTEMS

Sunmaster SG270 with SGPKIT270

Items Supplied with Cylinder			Items Supplied in SGPKIT270 (cont...)		
①	1	 PTR Valve	⑪	1	 Pump and Controller Assembly (includes 2 x 1/2 Kinco nut and olive, flow control valve and non return valve) Temperature sensor lead (31002710) included with assembly, but shown separately as item 12 for clarity 39001735
②	1	 Adaptor R 3/4 x Rp 1/2			
③	3	 Adaptor R 3/4 x Rp 3/4			
Items Supplied in SGPKIT270					
④	2	 R 3/4 Nipples 17201003	⑫	1	 Temperature Sensor with 2 m lead Part of Pump and Controller Assembly (39001735), but shown separately for clarity 31002710
⑤	1	 3/4 Kinco Olive 33001011	⑬	2	 Elbow 3/4 Rp x 3/4 G flexi 21201012
⑥	1	 3/4 Kinco Nut 16801018	⑭	2	 Fibre Washer 3/4 17401008
⑦	1	 Copper Tee 11603936	⑮	1	 Insulated Flexi Pipe 1080 mm 11601069
⑧	2	 1/2 Kinco Olive (*1 not needed) 33001012			
⑨	2	 1/2 Kinco Nut (*1 not needed) 16801012			
⑩	1	 Insulated Copper Extension Pipe 11603348	⑯	2	 Gas Booster Mounting Brackets 1 x tabs bent 26601098 1 x tabs unbent 26601096
- 1		Operation and Installation Manual 15401030	- 3		 Cable Ties 39601036
- 1		Booster and Pump Mounting Instruction Sheet 15401031	- 1	2	 Screws 22601048
- 1		Gas Booster Mounting Template 15401034			
- 1		RECS form 15401023			
- 1		Warranty booklet 15401024			
- 1		Standardsmark Sticker 15802091			
			-	1	 Saddle Clamp 27201015

*This kit is used for a variety of installations. Items marked with an * are not needed for this particular installation

Sunmaster SG270 and SG340 with SGPKIT3

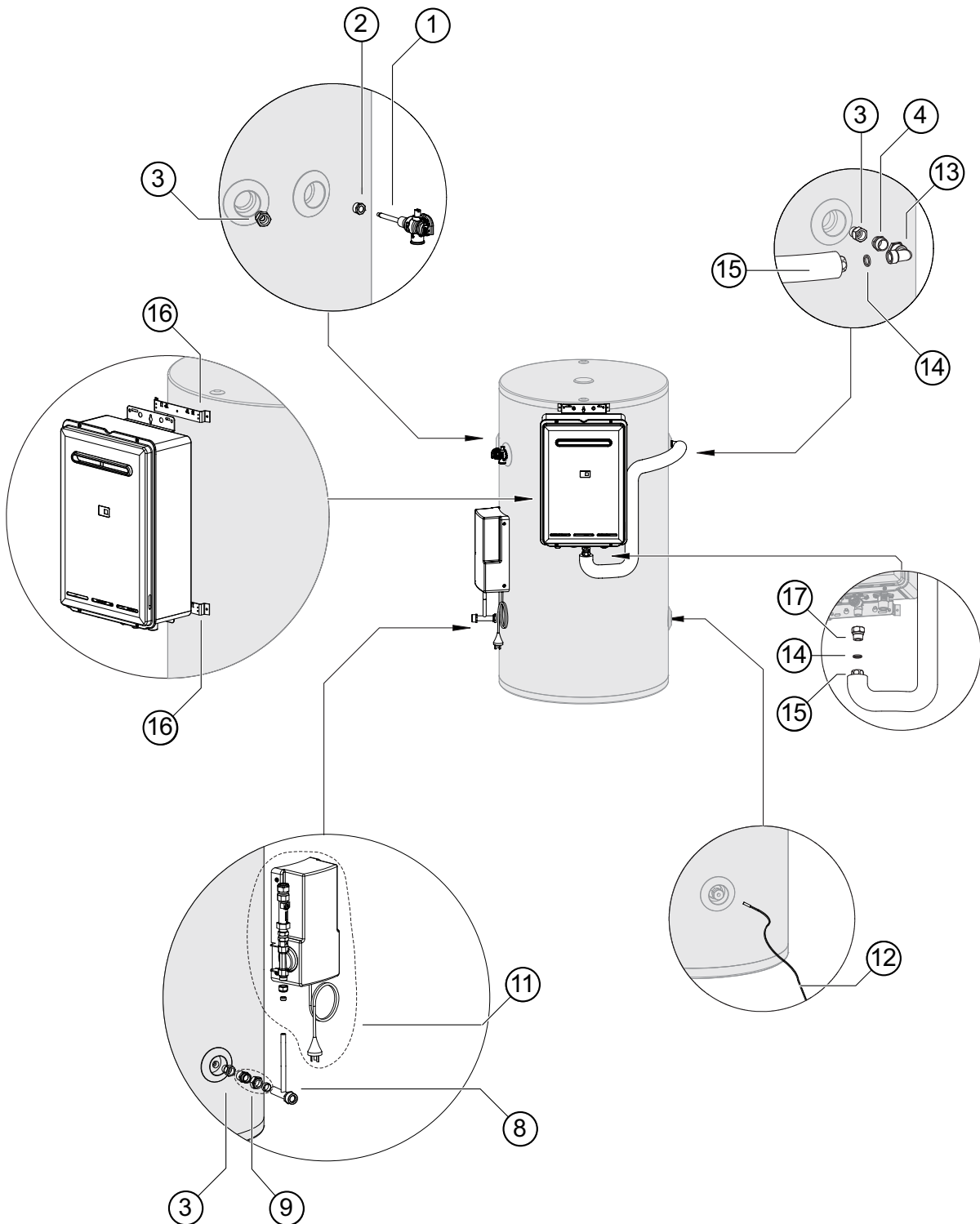
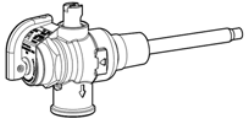





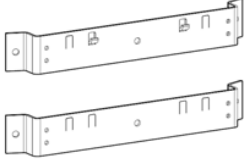

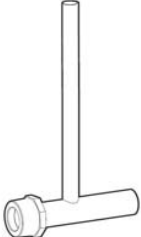

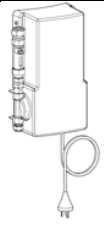





Figure 30 - Sunmaster Gas SG270 - SG340 with SGPKIT3

INSTALLATION & MAINTENANCE - GAS BOOSTED SYSTEMS

Sunmaster SG270 and SG340 with SGPKIT3

Items Supplied with Cylinder			Items Supplied in SGPKIT3 (cont...)		
①	1	 PTR Valve	⑬	1	 Elbow 3/4 Rp x 3/4 G flexi 21201012
②	1	 Adaptor R 3/4 x Rp 1/2	⑭	2	 Fibre Washer 3/4 17401008
③	3	 Adaptor R 3/4 x Rp 3/4	⑮	1	 Insulated Flexi Pipe 1080 mm 11601069
Items Supplied in SGPKIT3			⑯	2	 Gas Booster Mounting Brackets 1 x tabs bent 26601098 1 x tabs unbent 26601096
④	1	 R 3/4 Nipple 17201005	⑧	1	 Cold Inlet Copper T 11603921
⑨	1	 G3/4 (Comp) x R 3/4 union 32201713	⑪	1	 Pump and Controller Assembly (includes 2 x 1/2 Kinco nut and olive, flow control valve and non return valve) Temperature sensor lead (31002710) included with assembly, but shown separately as item 12 for clarity 39001735
⑫	1	 Temperature Sensor with 2 m lead Part of Pump and Controller Assembly (39001735), but shown separately for clarity 31002710	⑰	1	 Adaptor Rp 3/4 x G 3/4 (flexi) 16601006
-	-		-	14	 Screws 22601048
-	-		-	1	Operation and Installation Manual 15401021
-	-		-	1	Warranty booklet 15401024
-	-		-	1	RECS form 15401023
-	-		-	1	Gas Booster Mounting Template 15401034

INSTALLATION & MAINTENANCE - GAS BOOSTED SYSTEMS

INSTALLATION PROCEDURE

Install Solar Collectors

Position and install the solar collectors in accordance with the section 'INSTALLATION SOLAR COLLECTORS'.

1. Position Storage Cylinder

Position the hot water storage cylinder on a level base in accordance with the section 'STORAGE CYLINDER LOCATION'.

2. Connect PTR Valve

- Connect the PTR Valve in the location shown in the relevant diagram of **Figures 27 to 30**. Leave the valve outlet pointing down. Tighten the valve using the spanner flats - never use the valve body.
- The PTR Valve must be adequate for the thermal loading applied to the storage cylinder. In the case of gas boosted systems, the thermal load is applied only by the solar collectors. The continuous flow hot water heater does not apply thermal load to the storage cylinder. The potential solar output for the solar collectors at PTR Valve relief conditions is listed in **Table 3**.
- The PTR Valve pressure ratings vary according the cylinder specifications. The maximum heater input rating is 10.0 kW. The PTR valve rating **MUST EXCEED** the total input from the solar collectors. If it does not, the PTR valve **MUST** be exchanged for a model of higher capacity.
- *For example, for a gas boosted solar system with 3 x SP200A collectors, the thermal load is $3 \times 1.25 = 3.75 \text{ kW}$. This is less than 10.0 kW, hence the supplied PTR valve is of sufficient capacity.*
- Use Teflon thread tape on the valve, never use hemp or other sealing materials. Ensure the tape does not protrude past the end of the thread, which could result in it hanging over the end of the thread and blocking the water passage through the valve.

3. Mount Gas Booster

Mount the gas booster in accordance with the section 'GAS BOOSTER LOCATION & MOUNTING'.

4. Connect Fittings and Mount Pump Assembly

Connect fittings and pipe work as shown in the relevant diagram in **Figures 27 to 30**. Remove cover of pump box and attach pump box to cylinder using screws provided. **DO NOT** connect the power lead to power supply at this stage.

5. Install and Connect Flow and Return Pipe Work

Connect flow and return pipe work between storage cylinder and solar collector. Ensure that suitable pipe and insulation is used as described in the section "WATER PIPES".

6. Connect Temperature Sensor Leads

- The hot (longer) temperature sensor lead should be fitted into the air bleed / hot sensor lead assembly at the collector hot return connection as shown in **Figures 25 to 26**. It must be sealed in place with thermoplastic putty or silicone.
- Run the lead down the solar return pipe and connect it to the connection within the pump and controller assembly as shown in the diagram. Ensure the lead is protected from light. Figure 34 - Temperature Sensor Leads
- The cold (shorter) temperature sensor lead should be fitted as shown in the relevant diagram in **Figures 27 to 30**. It must be sealed in place with thermoplastic putty or silicone. The plug is then connected to the pump and controller assembly as shown in the diagram.
- Replace Pump Assembly Cover.

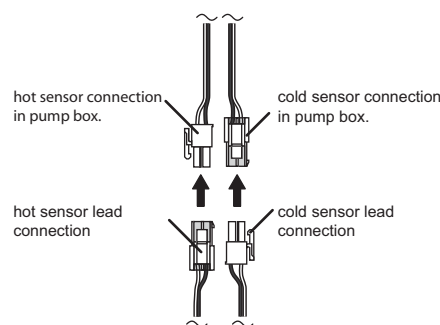

Figure 31 - Temperature Sensor Leads



IT IS IMPORTANT THAT THESE PROBES ARE INSTALLED AS SPECIFIED. FAILURE TO DO SO WILL LEAD TO MALFUNCTION OR LACK OF HOT WATER.

7. Cold Water Supply

- Connect cold water supply to the inlet 'T'. Ensure that the relevant valves as described in the section "VALVES AND FITTINGS" are fitted.
- Purge the cold water supply lines to remove air and swarf before final connection.

8. Relief Drain Lines

- Independent 15 mm copper pipes must be fitted to the drain outlets of the PTR and ECV. Each pipe must be open to atmosphere and run with a continual downward grade in a frost free environment to a visible discharge point. Drain lines must not exceed 9 metres in length.
- Valves or other restrictions **must not** be placed in the relief valve drain outlet line.



Some water will drip from the drain lines during heating of the water in the storage cylinder. It is recommended to discharge directly above a drain.

9. Hot Water Discharge

- Connect the hot water outlet of the gas booster to the pipe work supplying hot water to the premises.



A temperature limiting device may be required as detailed in the section "HOT WATER DELIVERY TEMPERATURE".

10. Connect Gas to Booster

- Connect a suitable gas supply and isolating valve to the gas booster. Follow instructions supplied with gas booster. Keep gas booster isolated at this stage.

FILLING THE SYSTEM



Ensure building occupants are warned to stay clear of the solar system components, building perimeter and roof since hot water or steam may be discharged from pipes or components.

1. Ensure the electric power supplies to the water heater and pump kit are switched 'OFF'.
2. Ensure the gas supply to the continuous flow water heater is isolated.
3. Turn 'ON' the hot water tap at the sink. Open the stop cock in the cold water mains supply line.
4. The entire system will now be filled with cold water. Most air will be dispelled through the tap. Some air needs to be bled from the air bleed valve on the collectors.
5. Turn 'OFF' the hot tap at the sink when water flows freely without air bubbles or air bursts. Check all connections for leakage and tighten if necessary. This applies especially to fittings in positions not easily assessed such as near the solar collectors. Operate the easing gear of both the PTR and ECV valves at the storage cylinder to ensure these valves are functional.



If leaks are detected the system must be drained and leaks repaired before the system is refilled. If this is necessary, cover the solar collectors with packaging cardboard or a tarp to prevent them from heating which could result in steam or hot water being discharged from fittings.

INSTALLATION & MAINTENANCE - GAS BOOSTED SYSTEMS

CHECKING SOLAR PUMP OPERATION

1. Ensure hot and cold sensors are connected as shown **Figure 31**.
2. Activate power supply.
3. Pumps will operate when solar energy is available to be collected. Pump operation can be checked by placing the end of a screw driver to the pump body and the other end of the screw driver near your ear.



The dip switches within the pump control box should not need to be adjusted.

If the solar pump does not activate the system can still be commissioned as detailed in these instructions, but solar preheating will not be available until the pump and controller operate.

ADJUSTING FLOW CONTROL VALVE

The purpose of the flow control valve is to allow the water flow rate through the collector collectors and storage cylinder to be controlled to optimise the performance of the system. The optimum flow rate for the system will depend on the type of system (electric or gas boost), the number of collector collectors, and the location of the installation (see the solar zone shown in **Figure 32**).



Figure 32 - Australian Solar Zones

The flow control valve needs to be adjusted while the pump is operating. The flow rate valve is read at the bottom of the baffle float as shown in **Figure 33** Using a flat bladed screw driver turn the screw on the valve until the value from **Table 9** is achieved.

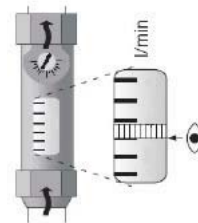

Figure 33 - Adjusting Flow Control Valve

The installer will need to set the flow rate to the value shown in **Table 9** below.

Table 9 - Optimum Flow Rate (Litres/min).

	No. of Collectors	Zones 1, 2 & 3	Zone 4
Gas Boosted	1	0.50	0.50
	2	1.25	1.25
	3	2.10	2.10

INSTALLATION & MAINTENANCE - GAS BOOSTED SYSTEMS

PRE SOLAR HEATING CHECKS

Before commencing solar heating of the water in the system ensure the following actions have been completed:

Solar Collectors

1. Are the solar collectors installed with the correct slope and orientation to the sun?
2. Is the installation finished neatly with the roof made good, all tiles and flashings in place?
3. Are the bolts tight on the roof framework?
4. Are all solar collector straps fitted and correctly anchored to the roof structure?
5. If leak testing completed and successful, have any covers been removed from the solar collectors?
6. Has operation of the solar pump been checked?
7. Have the hot and cold sensors and leads been positioned and connected correctly?

Gas Booster

1. Ensure the gas supply is isolated. Remove the test point screw located on the gas inlet connection and attach a pressure gauge.
2. Turn on the electrical power to the gas booster only (not the solar pump kit) and turn on the gas supply.
3. Ensure the cold water inlet ('trio') valve on the storage cylinder inlet is open. Open all available hot water taps.
4. Operate ALL other gas appliances at their maximum gas rate, in accordance with manufacturers instructions.



Ensure building occupants do not have access to hot water outlets during this procedure.

5. With all gas appliances in operation at the maximum gas rate, the pressure should read between 1.13 - 3.0 kPa on Natural Gas. On LPG the pressure should be 2.75 - 3.0 kPa. If the pressure is lower, the gas supply is inadequate and the appliance will not operate to specification. It is the installers responsibility to check the gas meter, service regulator and pipe work for correct operation/ sizing & rectify as required. Note that the gas regulator on the appliance is electronically controlled and factory pre-set. Under normal circumstances it DOES NOT need adjustment during installation. Make adjustments only if the gas booster is not operating correctly and all other possible causes for incorrect operation have been eliminated. Instructions for gas pressure setting are located in the pocket behind the front cover of the gas booster.
6. Close the hot water taps including the shower.
7. Check the hot water delivery temperature by placing a suitable thermometer at the hot water outlet closest to the gas booster. This is usually the hot water outlet in the kitchen. The delivery temperature should be greater than 55°C (this temperature allows for heat losses in pipe work). If the delivery temperature at the hot water outlet is lower than 55°C, check the delivery temperature at the outlet of the gas booster. It should be within 2°C of the set point, usually 60°C. If not, refer to the section '**Hot Water Delivery temperature**'.
8. Close the cold water inlet ('trio') valve on the storage cylinder inlet and inspect and clean the strainer. Repeat for the strainer connected at the inlet of the gas booster. This procedure may need to be repeated to ensure the strainers remains clear, especially on new installations.
9. Confirm the hot water delivery temperature from the gas booster. This is done by checking the hot water delivery temperature at an untempered outlet close to the water heater. This is usually the hot water outlet in the kitchen. The untempered hot water delivery should be between 55°C & 60°C.

INSTALLATION & MAINTENANCE - GAS BOOSTED SYSTEMS

Temperature Limiting Devices

1. Commission any temperature limiting devices in accordance with the instructions supplied by the manufacturer.
2. Confirm the hot water delivery temperature at a tempered water outlet. Tempered water outlets should be those supplying areas primarily used for the purposes of personal hygiene such as bathrooms. The hot water delivery temperature should not exceed 50°C or 45°C as detailed in the section '**Hot water delivery temperature**'.

SOLAR HEATING

1. Remove any cardboard or tarp covers that may have been placed over the solar collectors to prevent them from heating water during installation and commissioning.
2. Activate electrical power to both the gas booster and solar pump and controller. Solar heating of the water in the cylinder will now commence when sufficient solar radiation is available.

FINISHING THE INSTALLATION

After testing is completed explain to the householder the functions and operation of solar water heater components. Also explain to the householder the importance of carrying out Maintenance as per separate warranty document.

Leave this Manual with the householder.

Remind the householder to complete the 'Warranty Certificate' provided in the separate warranty document.

DRAINING INSTRUCTIONS

1. The power supply to the gas booster and pump controller must be switched off and fuse(s) removed.
2. Close the cold water mains supply stop cock.
3. Open a hot tap to relieve pressure.
4. Disconnect the hot outlet near the top of the storage cylinder.
5. Disconnect the cold inlet near the bottom of the storage cylinder.
6. Disconnect the connection between the solar 'flow pipe' and solar pump.
7. Disconnect the connection between the solar 'return pipe' and the cylinder.
8. The cylinder and solar collectors will now drain completely.

INSTALLATION & MAINTENANCE - ELECTRIC BOOSTED SYSTEMS

OVERVIEW OF SYSTEM COMPONENTS

The range of electric boosted solar hot water systems include all the components shown in **(Refer to the appropriate figure depending on cylinder type / size and kit)**.

The pump kit and associated plumbing connections are factory pre-assembled. All other components and fittings will require connection on site.

ELECTRIC SUPPLY



Electrical connection must be carried out by a qualified person and in accordance with AS3000 'Wiring Rules' and local authority requirements.

All electrically boosted solar hot water heating elements must be connected to an independent, fused, AC 240V 50 Hz power supply with an isolating switch installed at the switch board. Ensure the household wiring to the system is capable of withstanding the system electrical load (refer to specifications for electrical load details). Twin element models are factory wired for 'non' simultaneous' operation.

The solar pump kit requires an AC 240V power supply from a 10A earthed power point adjacent to the storage cylinder. For outdoor installations this power point must be weatherproof. This power supply must be independent from the power supply to any heating elements.

HOT WATER STORAGE AND DELIVERY TEMPERATURES

Australian Standards require a minimum storage cylinder thermostat set point of 60°C.

Sunmaster SE160, SE200 or SE315 WITH SEPKIT

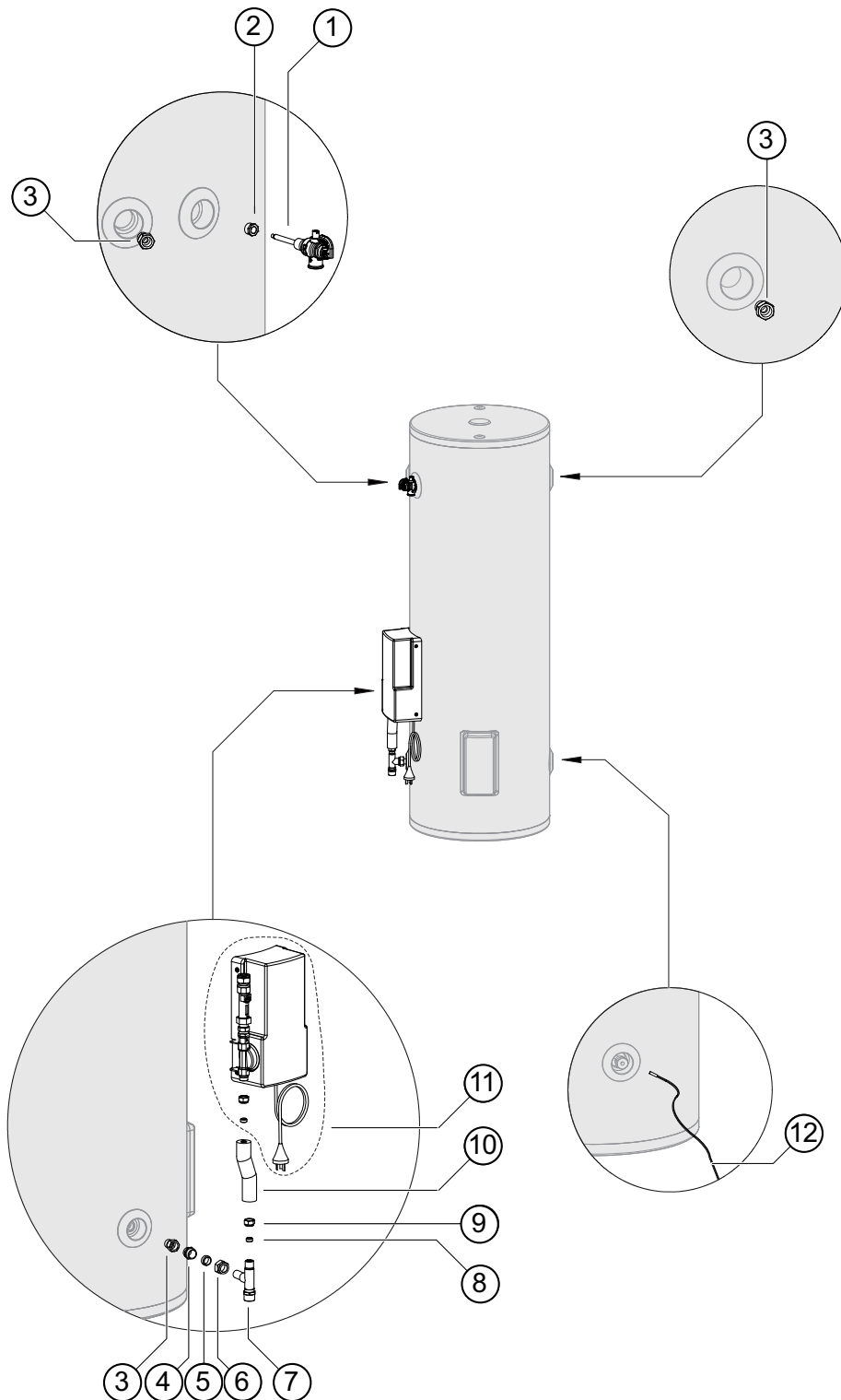
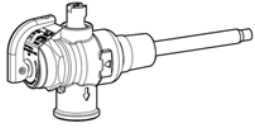





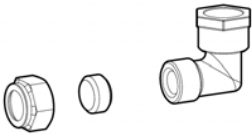





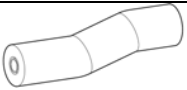

Figure 34 - Sunmaster Electric SE160, SE200 or SE315 with SEPKIT

INSTALLATION & MAINTENANCE - ELECTRIC BOOSTED SYSTEMS

Sunmaster SE160, SE200 or SE315 with SEPKIT

Items Supplied with Cylinder			Items Supplied in SEPKIT (cont...)		
①	1	 PTR Valve	⑪	1	 Pump and Controller Assembly (includes 2 x 1/2 Kinco nut and olive, flow control valve and non return valve) Temperature sensor lead (31002710) included with assembly, but shown separately as item 12 for clarity 39001735
②	1	 Adaptor R 3/4 x Rp 1/2			
③	3	 Adaptor R 3/4 x Rp 3/4			
Items Supplied in SEPKIT					
④	2	 R 3/4 Nipples 17201003 (*1 not needed)	⑫	1	 Temperature Sensor with 2 m lead Part of Pump and Controller Assembly (39001735), but shown separately for clarity 31002710
⑤	1	 3/4 Kinco Olive 33001011	*	2	 G 3/4 (comp) x Rp 3/4 elbow 21201026
⑥	1	 3/4 Kinco Nut 16801018	-	6	 Screws 22601048
⑦	1	 Copper T 11603936	-	3	 Cable Ties 39601036
⑧	2	 1/2 Kinco Olive 33001012 (*1 not needed)	-	1	Operation and Installation Manual 15401030
⑨	2	 1/2 Kinco Nut 16801012 (*1 not needed)	-	1	Warranty booklet 15401024
⑩	1	 Insulated Copper Extension Pipe 11603348	-	1	RECS form 15401023
			-	1	Standardsmark Sticker 15802091

*This kit is used for a variety of installations. Items marked with an * are not needed for this particular installation

Sunmaster SE160, SE200 or SE315 with USKIT1

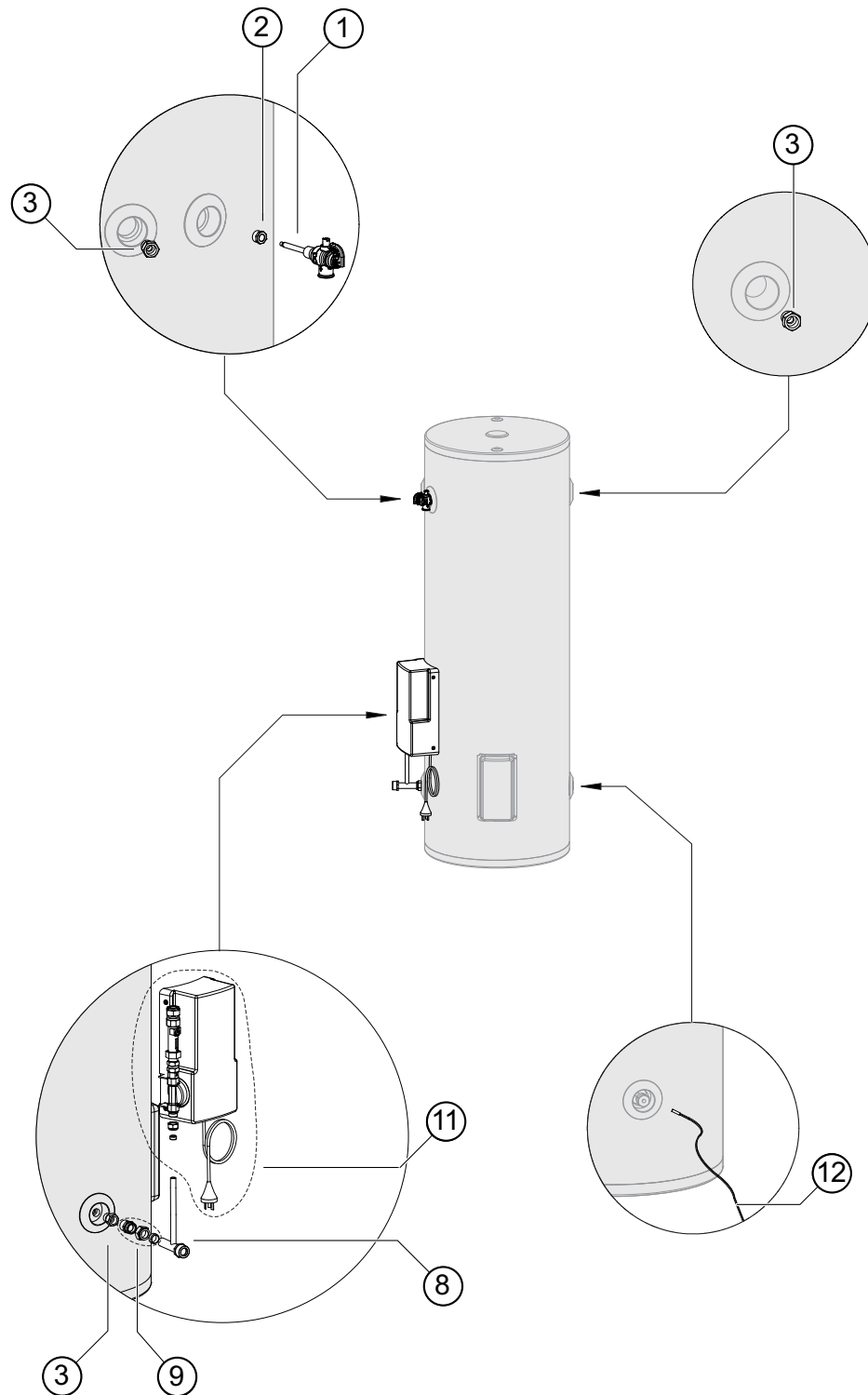
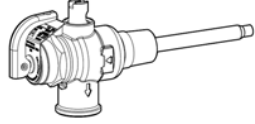









Figure 35 - Sunmaster Electric SE160, SE200 or SE315 with USKIT1

INSTALLATION & MAINTENANCE - ELECTRIC BOOSTED SYSTEMS

Sunmaster SE160, SE200 or SE315 with USKIT1

Items Supplied with Cylinder			Items Supplied in USKIT1		
①	1	 <p>PTR Valve</p>	⑧	1	 <p>Cold Inlet Copper T 11603921</p>
②	1	 <p>Adaptor R$\frac{3}{4}$ x Rp$\frac{1}{2}$</p>	⑨	1	 <p>G$\frac{3}{4}$ (Comp) x R $\frac{3}{4}$ union 32201713</p>
③	3	 <p>Adaptor R$\frac{3}{4}$ x Rp$\frac{3}{4}$</p>	⑪	1	 <p>Pump and Controller Assembly (includes 2 x $\frac{1}{2}$ Kinco nut and olive, flow control valve and non return valve) Temperature sensor lead (31002710) included with assembly, but shown separately as item 12 for clarity 39001735</p>
			⑫	1	 <p>Temperature Sensor with 2 m lead Part of Pump and Controller Assembly (39001735), but shown separately for clarity 31002710</p>
	-			6	 <p>Screws 22601048</p>
	-			1	<p>Operation and Installation Manual 15401021</p>
	-			1	<p>Warranty booklet 15401024</p>
	-			1	<p>RECS form 15401023</p>

Prestige Electric with USKIT1

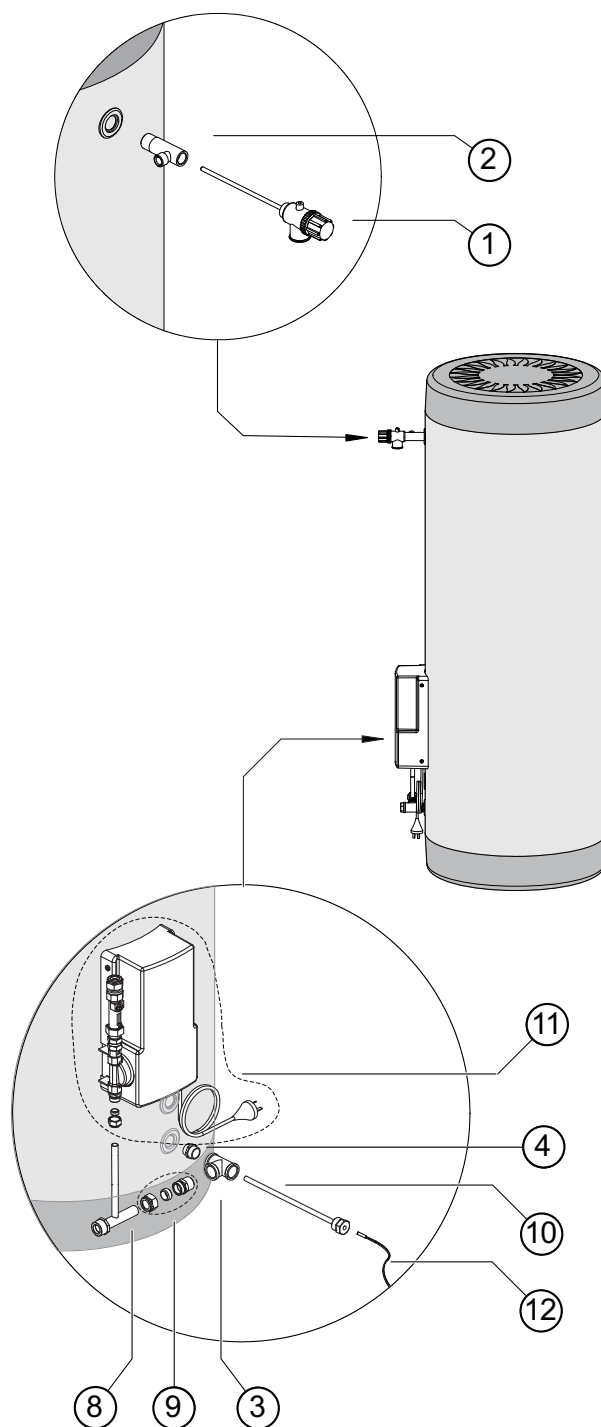
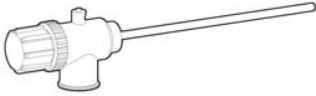
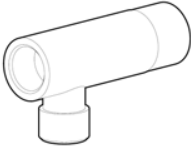
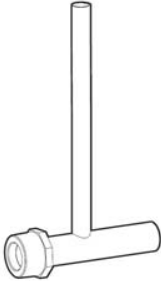









Figure 36 - Split Prestige Electric with USKIT1

INSTALLATION & MAINTENANCE - ELECTRIC BOOSTED SYSTEMS

Prestige MkII Electric with USKIT1

Items Supplied with Cylinder			Items Supplied in USKIT1		
①	1	 PTR Valve 11004784			
②	1	 Hot outlet T 19001018	⑧	1	 Cold Inlet Copper T 11603921
③	1	 T ¾ Rp 19001011			
④	1	 Nipple R ¾ 17201005	⑨	1	 G3/4 (Comp) x R ¾ union 32201713
⑩	1	 250 mm Sheath Thermocouple 10204721	⑪	1	 Pump and Controller Assembly (includes 2 x ½ Kinco nut and olive, flow control valve and non return valve) Temperature sensor lead (31002710) included with assembly, but shown separately as item 12 for clarity 39001735
			⑫	1	 Temperature Sensor with 2 m lead Part of Pump and Controller Assembly (39001735), but shown separately for clarity 31002710
	-			6	 Screws 22601048
	-			1	Operation and Installation Manual 15401021
	-			1	Warranty booklet 15401024
	-			1	RECS form 15401023

INSTALLATION & MAINTENANCE - ELECTRIC BOOSTED SYSTEMS

INSTALLATION PROCEDURE

1. Install Solar Collectors

Position and install the solar collectors in accordance with the section 'INSTALLATION OF SOLAR COLLECTORS'.

2). Position Storage Cylinder

Position the hot water storage cylinder on a level base in accordance with the section "STORAGE CYLINDER LOCATION"

3. Connect PTR Valve

- Connect the PTR Valve in the location shown in the relevant diagram of **Figures 34 to 36**.
Leave the valve outlet pointing down. Tighten the valve using the spanner flats - never use the valve body.
- The PTR Valve must be adequate for the thermal loading applied to the storage cylinder. In the case of gas boosted systems, the thermal load is applied only by the solar collectors. The continuous flow hot water heater does not apply thermal load to the storage cylinder. The potential solar output for the solar collectors at PTR Valve relief conditions is listed in **Table 3**.
- The PTR Valve pressure ratings vary according the cylinder specifications. The maximum heater input rating is 10.0 kW. The PTR valve rating **MUST EXCEED** the total input from the solar collectors. If it does not, the PTR valve **MUST** be exchanged for a model of higher capacity.
- *For example, for a gas boosted solar system with 3 x SP200A collectors, the thermal load is $3 \times 1.25 = 3.75 \text{ kW}$. This is less than 10.0 kW, hence the supplied PTR valve is of sufficient capacity.*
- Use Teflon thread tape on the valve, never use hemp or other sealing materials. Ensure the tape does not protrude past the end of the thread, which could result in it hanging over the end of the thread and blocking the water passage through the valve.

4. Connect Fittings and Mount Pump Assembly

- Connect fittings and pipe work as shown in the relevant diagram in **Figures 34 to 36**. Remove cover of pump box and attach pump box to cylinder using screws provided. Do not connect the power lead to power supply at this stage.

5. Install and Connect Flow and Return Pipe Work

- Connect flow and return pipe work between storage cylinder and solar collector. Ensure that suitable pipe and insulation is used as described in the section "WATER PIPES".

6. Connect Temperature Sensor Leads

- The hot (longer) temperature sensor lead should be fitted into the air bleed / hot sensor lead assembly at the collector hot return connection as shown in **Figure 25 to 26**. It must be sealed in place with thermoplastic putty or silicone.
- Run the lead down the solar return pipe and connect it to the connection within the pump and controller assembly as shown in the diagram below. Ensure the lead is protected from light.
- The cold (shorter) temperature sensor lead should be fitted as shown in the relevant diagram in **Figures 34 to 36**. It must be sealed in place with thermoplastic putty or silicone. The plug is then connected to the pump and controller assembly as shown in the diagram.
- Replace pump assembly cover.

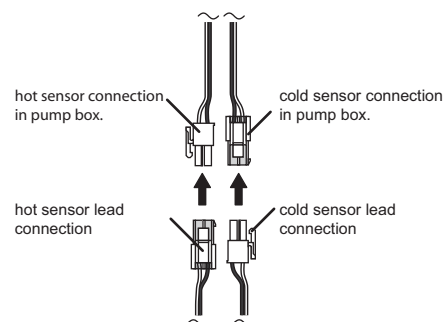

Figure 31 - Temperature Sensor Leads



**IT IS IMPORTANT THAT THESE PROBES ARE INSTALLED AS SPECIFIED.
FAILURE TO DO SO WILL LEAD TO MALFUNCTION OR LACK OF HOT WATER.**

7. Cold Water Supply

- Connect cold water supply to the inlet 'T'. Ensure that the relevant valves as described in the section "VALVES AND FITTINGS" are fitted.
- Purge the cold water supply lines to remove air and swarf before final connection.

8. Relief Drain Lines

- Independent 15 mm copper pipes must be fitted to the drain outlets of the PTR and ECV. Each pipe must be open to atmosphere and run with a continual downward grade in a frost free environment to a visible discharge point. Drain lines must not exceed 9 metres in length.
- Valves or other restrictions **must not** be placed in the relief valve drain outlet line.



Some water will drip from the drain lines during heating of the water in the storage cylinder. It is recommended to discharge directly above a drain.

9). Hot Water Discharge

- Connect the hot water outlet of the storage cylinder to the pipe work supplying hot water to the premises.



A temperature limiting device may be required as detailed in the section "HOT WATER DELIVERY TEMPERATURE".

10).Electrical Supply Connections



The power supply to the heating elements and pump kit must not be activated until the system is filled with water.

- Twin element storage cylinders are wired for non simultaneous operation. The electric supply should be 'Off-Peak' (overnight) to the bottom heating unit and continuous to the top heating unit.
- The power supply to a single element model can be either Off-Peak (overnight), Extended Off-Peak (overnight and day) or continuous, depending on the tariffs available from the local electricity supply authority. The Off-Peak (overnight) power supply minimises the cost of any required electric boosting. Discuss power supply requirements with the end user and electricity supply authority as required.

11).Connections for single element heaters

Figures 17 & 18 shows the wiring detail for single and twin element heaters.

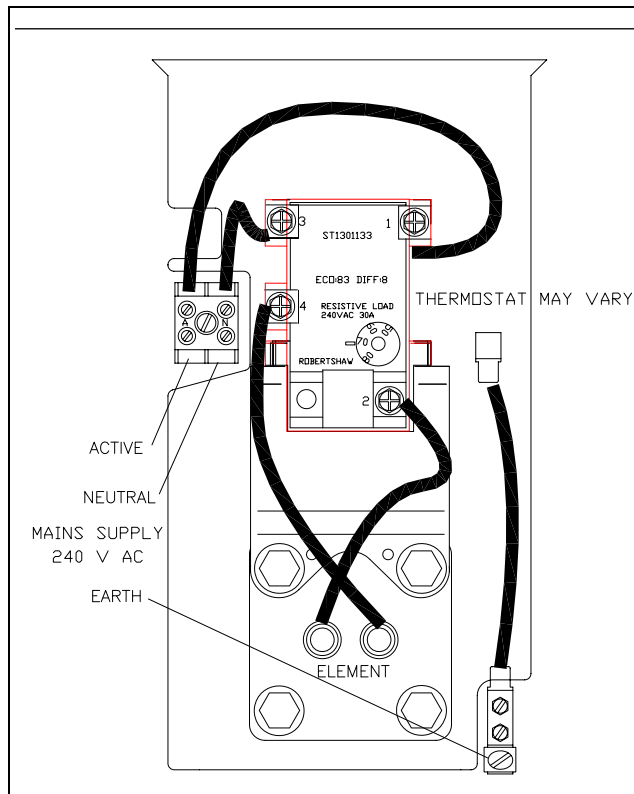

Figure 37 - Wiring detail - single element heaters

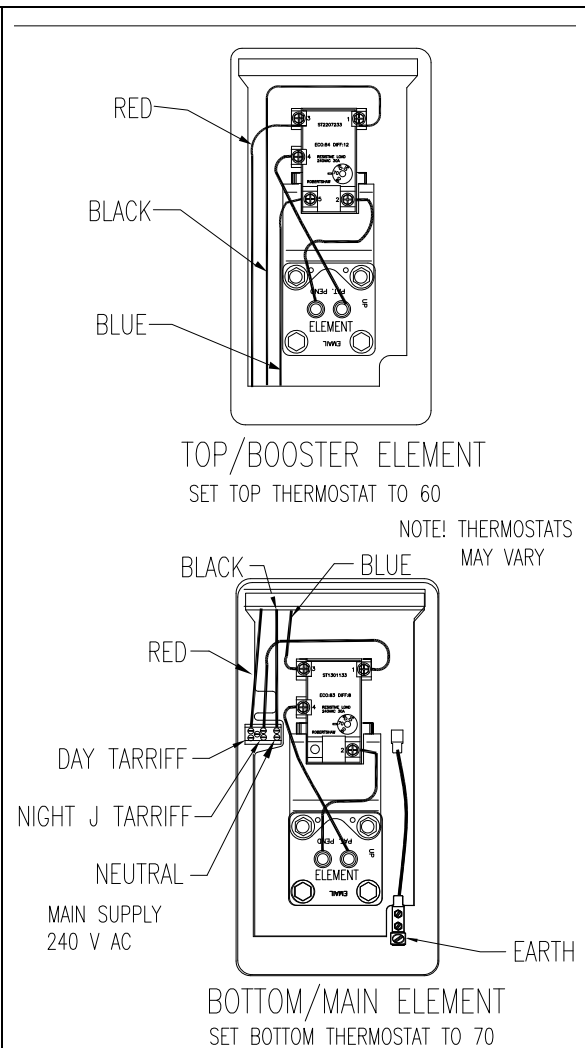

Figure 38 - Wiring detail for twin element heaters

A flexible 20 mm conduit is required for the electrical cable to the storage cylinder. The conduit is to be connected to the unit with a 20mm terminator. Connect the power supply wires directly to the terminal block and earth tab connections ensuring there are no excess wire loops inside the front cover.

Connections for twin element heaters

Figure 38 - shows the wiring detail for twin element heaters wired for non simultaneous operation.

A flexible 20 mm conduit is required for the electrical cable to the storage cylinder. All wiring passes through the lower entry. The conduit is to be connected to the unit with a 20 mm terminator. A common neutral is used. Connect the power supply wires directly to the terminal block and earth tab connections ensuring there are no excess wire loops inside the front cover.

Heating Element Thermostat Temperature Settings

Australian Standards require a minimum thermostat set point of 60°C to inhibit the growth of Legionella Pneumophila bacteria. These standards also require that the thermostat set point of water heaters fitted with an upper (or booster) element is at least 10°C below the thermostat set point of the lower element. In the interests of durability, the thermostat set point for storage cylinders should not exceed 70°C. Hence, in systems with a single heating element only the thermostat set point should be at least 60°C and no greater than 70°C. In systems with both a lower and upper (or booster) element, the thermostat set point of the lower element should be between 60° and 70°C and the upper element 50°C - 60°C.

FILLING THE SYSTEM



Ensure building occupants are warned to stay clear of the solar system components, building perimeter and roof since hot water or steam may be discharged from pipes or components.

1. Ensure the electric power supplies to the water heater and pump kit are switched 'OFF'.
2. Ensure the gas supply to the continuous flow water heater is isolated.
3. Turn 'ON' the hot water tap at the sink. Open the stop cock in the cold water mains supply line.
4. The entire system will now be filled with cold water. Most air will be dispelled through the tap. Some air needs to be bled from the air bleed valve on the collectors.
5. Turn 'OFF' the hot tap at the sink when water flows freely without air bubbles or air bursts. Check all connections for leakage and tighten if necessary. This applies especially to fittings in positions not easily assessed such as near the solar collectors. Operate the easing gear of both the PTR and ECV valves at the storage cylinder to ensure these valves are functional.



If leaks are detected the system must be drained and leaks repaired before the system is refilled. If this is necessary, cover the solar collectors with packaging cardboard or a tarp to prevent them from heating which could result in steam or hot water being discharged from fittings.

CHECKING SOLAR PUMP OPERATION

1. Ensure hot and cold sensors are connected as shown in *Figure 31*.
2. Activate power supply.
3. Pumps will operate when solar energy is available to be collected. Pump operation can be checked by placing the end of a screw driver to the pump body and the other end of the screw driver near your ear.



The dip switches within the pump control box should not be adjusted.
If the solar pump does not activate the system can still be commissioned as detailed in these instructions, but solar preheating will not be available until the pump and controller operate.

ADJUSTING FLOW CONTROL VALVE

The purpose of the flow control valve is to allow the water flow rate through the collector collectors and storage cylinder to be controlled to optimise the performance of the system. The optimum flow rate for the system will depend on the type of system (electric or gas boost), the number of collector collectors, and the location of the installation (see the solar zone shown in *Figure 32*).



Figure 32 - Australian Solar Zones

The flow control valve needs to be adjusted while the pump is operating. The flow rate valve is read at the bottom of the baffle float as shown in *Figure 33*. Using a flat bladed screw driver turn the screw on the valve until the value from **Table 10** is achieved.

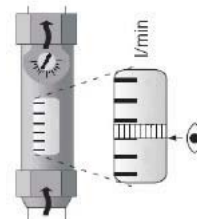

Figure 33 - Adjusting Flow Control Valve

The installer will need to set the flow rate to the value shown in **Table 10** below.

Table 10 - Optimum Flow Rate (Litres/min).

	No. of Collectors	Zones 1, 2 & 3	Zone 4
Electric Boosted	1	0.50	0.50
	2	1.00	0.65
	3	1.25	1.00

PRE SOLAR HEATING CHECKS

Before commencing solar heating of the water in the system ensure the following actions have been completed:

Solar Collectors

1. Are the solar collectors installed with the correct slope and orientation to the sun?
2. Is the installation finished neatly with the roof made good, all tiles and flashings in place?
3. Are the bolts tight on the roof framework?
4. Are all solar collector straps fitted and correctly anchored to the roof structure?
5. If leak testing completed and successful, have any covers been removed from the solar collectors?
6. Has operation of the solar pump been checked?
7. Have the hot and cold sensors and leads been positioned and connected correctly?

Electric Heating Elements

1. In systems with a single heating element only has the thermostat set point been set to at least 60°C and no greater than 70°C.
2. In systems with both a lower and upper (or booster) element, has the thermostat set point of the lower element been set to at least 60° and no greater than 70°. Has the upper element been set to 10° less than the lower element? .

Temperature Limiting Devices

1. Commission any temperature limiting devices in accordance with the instructions supplied by the manufacturer.
2. Confirm the hot water delivery temperature at a tempered water outlet. Tempered water outlets should be those supplying areas primarily used for the purposes of personal hygiene such as bathrooms. The hot water delivery temperature should not exceed 50°C or 45°C as detailed in the section '**Hot water delivery temperature**'.

SOLAR HEATING

1. Remove any cardboard or tarp covers that may have been placed over the solar collectors to prevent them from heating water during installation and commissioning.
2. Activate electrical power to both the gas booster and solar pump and controller. Solar heating of the water in the cylinder will now commence when sufficient solar reduction is available.

Auxiliary Energy Supply

1. Connect the electrical element to the power supply (off peak if available).
2. When the system is full of water turn on electrical supply to element.

FINISHING THE INSTALLATION

After testing is completed explain to the householder the functions and operation of solar water heater components. Also explain to the householder the importance of carrying out Maintenance as per separate warranty document.

Leave this Manual with the householder.

Remind the householder to complete the 'Warranty Certificate' provided in the separate warranty document.

DRAINING INSTRUCTIONS

INSTALLATION & MAINTENANCE - ELECTRIC BOOSTED SYSTEMS

1. The power supply to the element and pump controller must be switched off and fuse(s) removed.
2. Close the cold water mains supply stop cock.
3. Open a hot tap to relieve pressure.
4. Disconnect the hot outlet near the top of the storage cylinder.
5. Disconnect the cold inlet near the bottom of the storage cylinder.
6. Disconnect the connection between the solar 'flow pipe' and solar pump.
7. Disconnect the connection between the solar 'return pipe' and the cylinder.
8. The cylinder and solar collectors will now drain completely.

NOTES

NOTES

Rinnai

superiorsolar

hot water | solar power | pool heating

Unit 2/10
Enterprise Close
West Gosford
2250
tel : 4323 9050

Rinnai Australia Pty. Ltd. ABN 74 005 138 769

Head Office

10-11 Walker Street,
Braeside, Victoria 3195
P.O. Box 460
Tel: (03) 9271 6625
Fax: (03) 9271 6622

Rinnai has a Service and Spare Parts network with personnel who are fully trained and equipped to give the best service on your Rinnai appliance. If your appliance requires a service, please call our National Help Line.

Internet: www.rinnai.com.au
E-mail: enquiry@rinnai.com.au

National Help Line

Spare Parts & Technical Info
Tel: 1300 555 545*
Fax: 1300 300 141*

**Cost of a local call Higher from mobile or public phones.*

Hot Water Service Line
Tel: 1800 000 340

15401021