















-  On-roof
-  Framed modules
-  Orientation portrait
-  Orientation landscape
-  Snow load  
 $\leq 1,4 \text{ kN/m}^2$
-  Wind load  
 $\leq 60 \text{ m/s}$
-  Three Tab Shingle
-  Plain tile
-  Slate
-  Double Roman tile
-  Metal roof
-  **10**  
YEARS  
Material warranty

## Conergy SunTop III

Instructions for  
professional  
installation

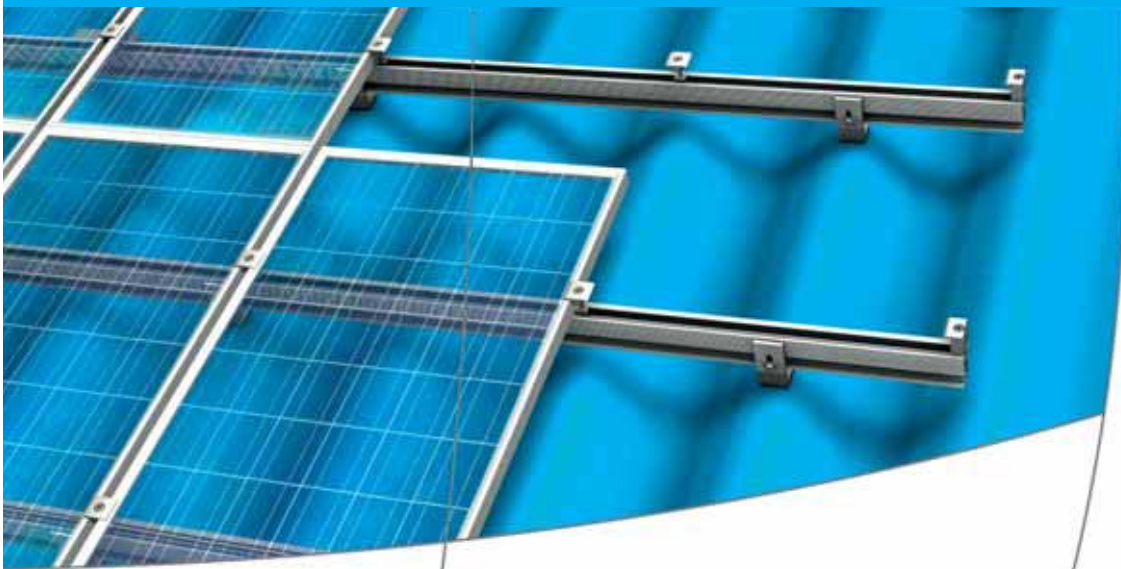

---

# INTRODUCTION

---

Dear customer,

**Thank you for choosing SunTop III, the revolutionary on-roof racking system for pitched roofs.**

Please read the installation instructions and familiarise yourself with the system components before beginning installation. During installation and especially when working on the roof, be sure to observe appropriate safety regulations and all applicable national and/or local roofing regulations.

The installer is solely responsible for:

- Complying with all applicable local or national building codes;
- Ensuring that SunTop III and other products are appropriate for the particular installation and the installation environment;
- Ensuring that the roof, its rafters, connections and other structural support members can support the array under building live load conditions (this total assembly is hereafter referred to as the roof rafter assembly);
- Using only SunTop III parts and installer-supplied parts as specified by Conergy – substitution of parts may void the warranty;
- Ensuring that roof attachments have adequate pullout strength and shear capacities as installed;
- Maintaining the waterproof integrity of the roof, including selection of appropriate flashing;
- Ensuring safe installation of all electrical aspects of the PV array;
- Verifying that other local factors – including seismic loads - do not materially affect installation design when designs are predicated upon local wind and snow loads only.

The SunTop III system is composed of aluminium and stainless steel components. If the potential for galvanic corrosion exists at your installation site, or if your installation site is located in a severely corrosive environment, please contact Conergy Pty Limited for support in designing your installation.

If your installation is outside Australia or New Zealand or if you need further assistance, consult a local professional engineer or your local building authority.

Conergy has brought over 10 years of field experience and German engineering together to form our unique, patented aluminium rails and Quickstone™ enabling faster, simpler installations.

**We hope that you will enjoy working with the SunTop III.**

**Your Conergy team**

## IMPORTANT SAFETY INSTRUCTIONS

### ▲WARNING

**INSTALLATION OF THIS PRODUCT IS INTENDED TO BE PERFORMED BY PROFESSIONALLY TRAINED INSTALLERS ONLY.** Any attempt to install this product by an unqualified individual could result in death or serious injury.

# 1. INSTALLATION PREPARATION

## Overview of system components

- (a) Conergy rail
- (b) Inter-module clamp
- (c) Roof attachment  
(L-bracket pictured)
- (d) Splice
- (e) Module end clamp

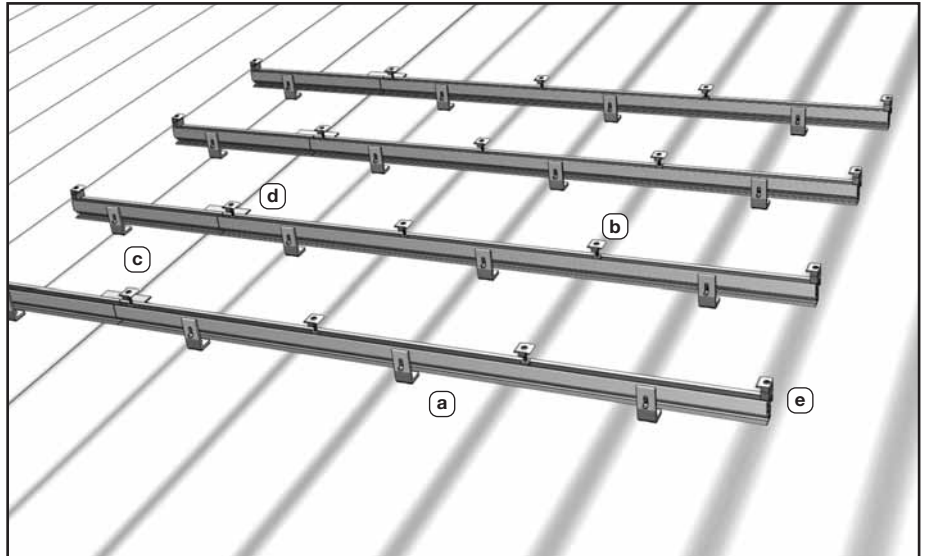

## Planning the array layout

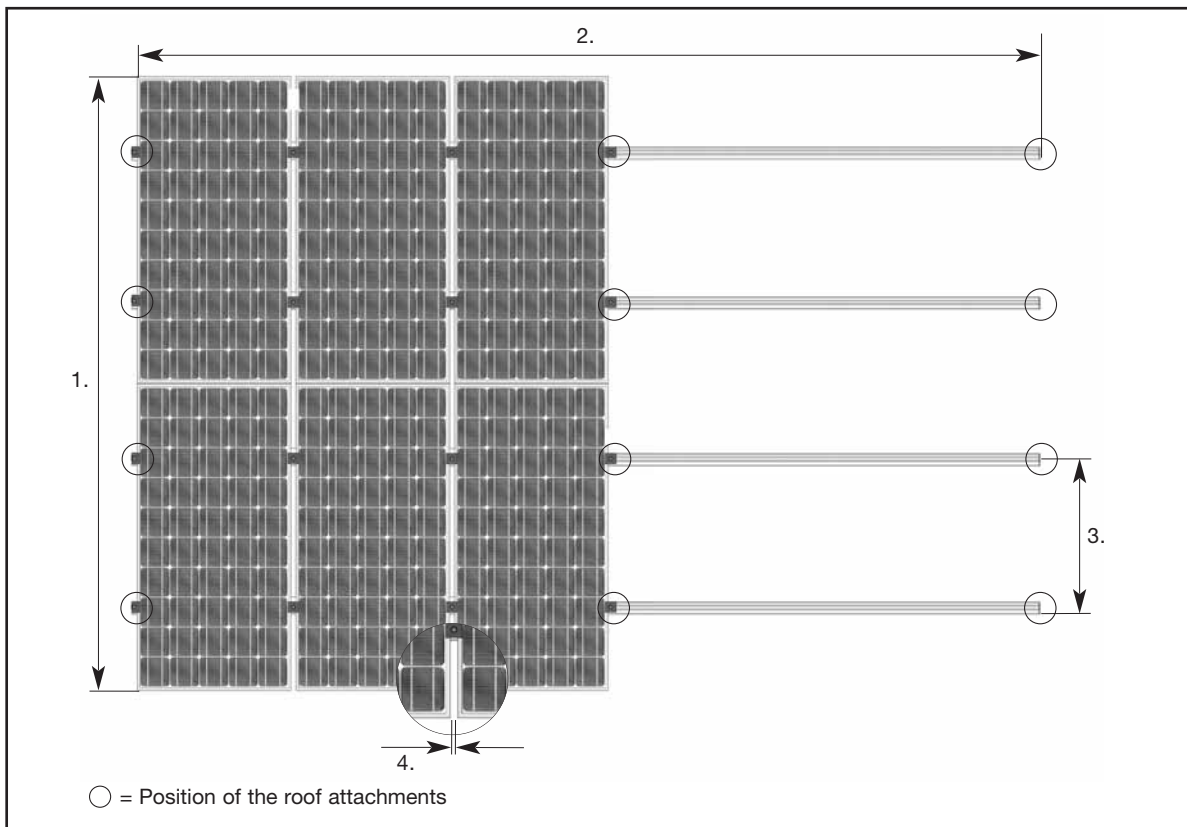

## Overview of required tools

- | 6 mm allen key
- | Cordless drill
- | Grinder with stone disk for tile roof
- | 17 mm box or socket and open-end wrenches for hanger bolt installations
- | 13 mm open-end wrench for flat tile and slate roof hook installations
- | Various wood screw drivers for roof hook installations, including phillips, metric hex, and torx head drivers.

## Planning the array layout

1. Array height = number of modules in the vertical direction x module height
2. Array width = number of modules in horizontal direction x (module width + 18 mm) + 32 mm
3. Vertical spacing of the roof attachment = approx.  $\frac{1}{2}$  of module height
4. Distance between the modules: 18 mm

## 2. INSTALLATION

### 1. Installing L-bracket on corrugated metal roofs

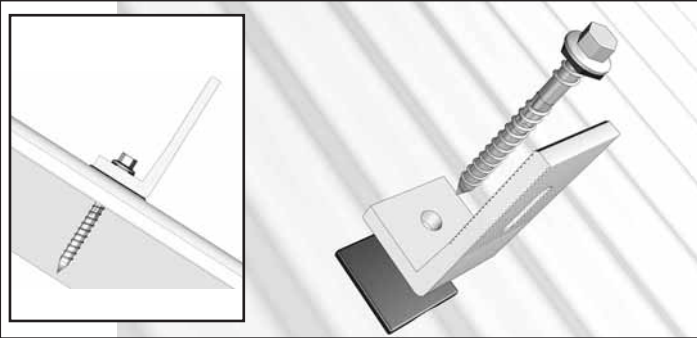

Mark L-bracket installation points, and ensure L-bracket are positioned over centers of rafters. Drill pilot holes for lag screws. Using butyl tape or other caulking method to

### 2. Installing L-bracket on corrugated metal roofs

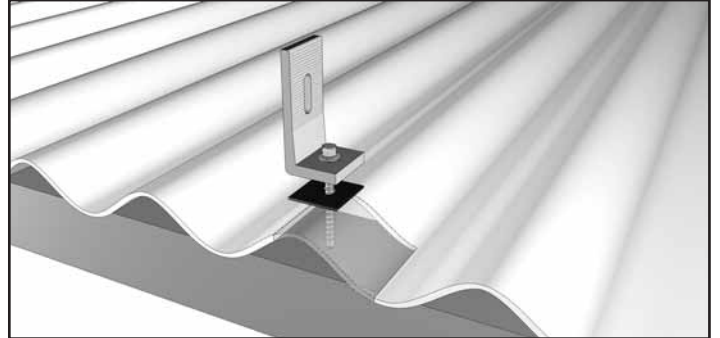

ensure watertight connections, secure L-bracket to roof with lag screws.

### CAUTION

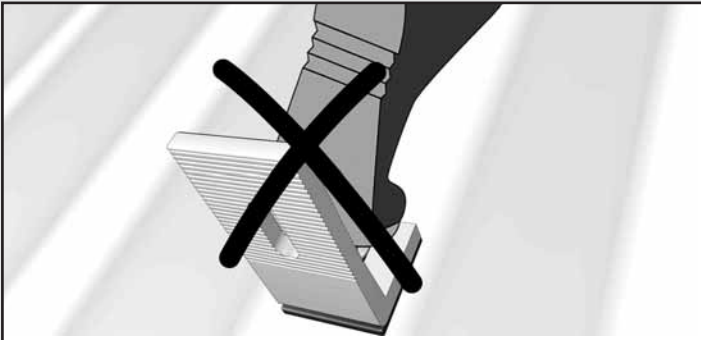

**Do not step on fitted roof attachments.** Stepping on roof attachments may damage underlying roof materials.

### 3. Installing roof hooks on double roman tile roofs

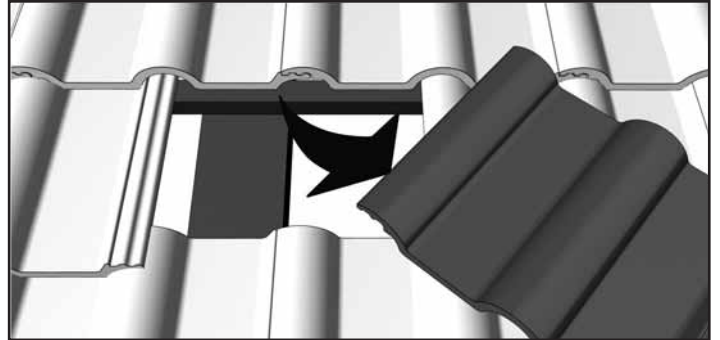

Mark roof hook installation points. Remove tiles at installation points, or simply push them up if possible.

### 4. Installing roof hooks on double roman tile roofs

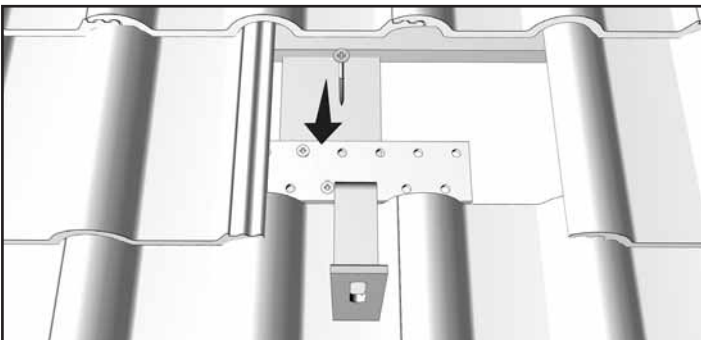

At each installation point, attach roof hooks to rafters using supplied wood screws. Use at least three wood screws per roof hook.

### Important information for all roof hook installations

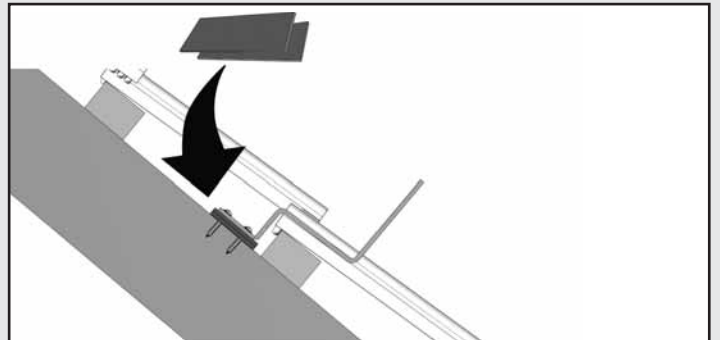

Roof hooks must mount flush to rafters and lay flat against lower tiles. If necessary, use wood shims to ensure proper fit against rafters and tiles

## 2. INSTALLATION

### 5. Installing roof hooks on double roman tile roofs

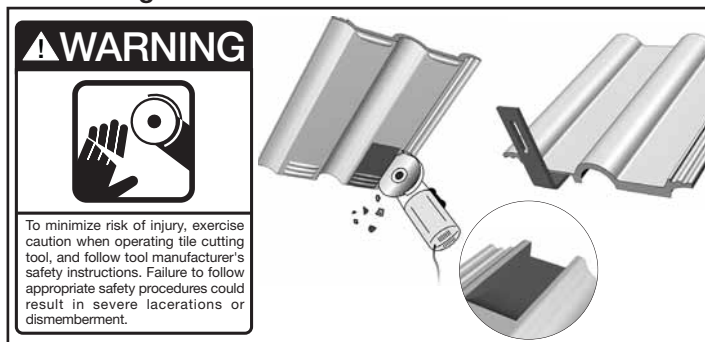

Tiles covering roof hooks should lie flat against lower tiles after roof hook installation. If necessary, cut recesses in upper tiles to accommodate roof hooks, and to enable upper tiles to lie flat against lower tiles.

### 6. Installing plain tile and slate roof hooks

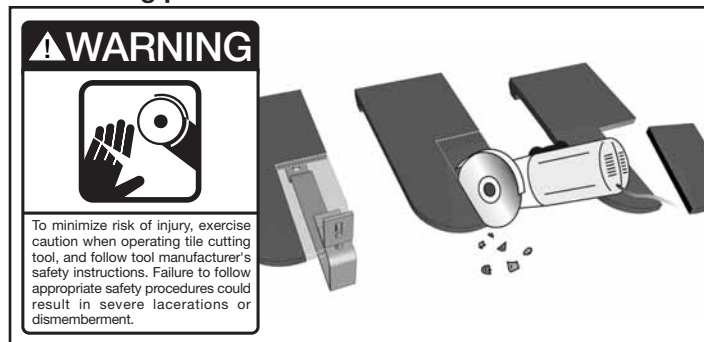

Mark roof hook installation points, and cut recesses for hooks into plain tiles/slate at each installation point.

### 7. Installing plain tile and slate roof hooks

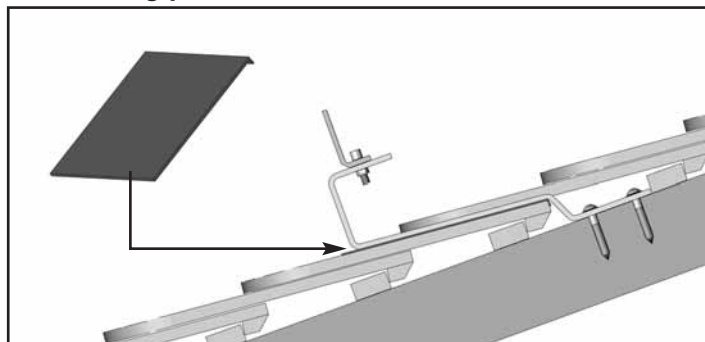

Install sheet metal flashing underneath roof hooks. Cut flashing to overlap recesses in tile/slate by at least 20 mm. Attach roof hooks to rafters using supplied wood screws.

### Using Quickstone technology

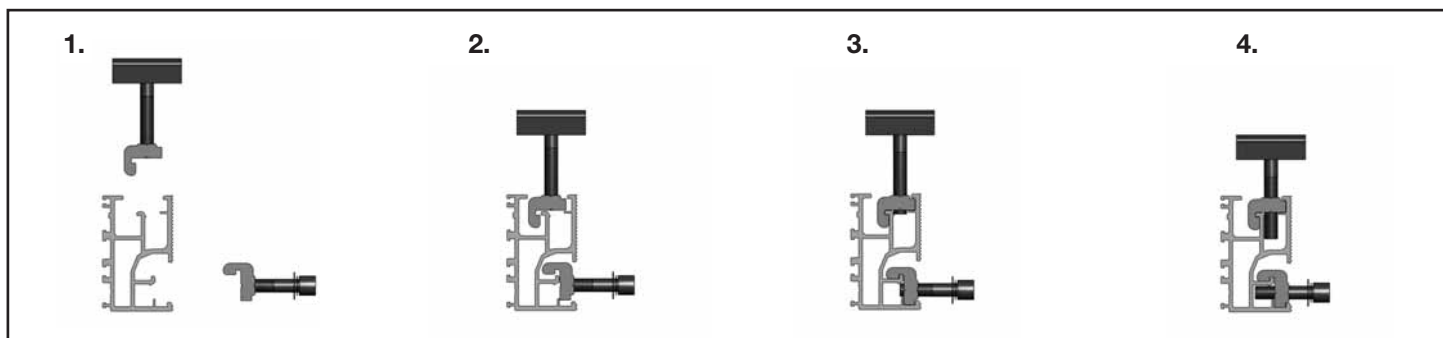

Quickstones are the specialized nuts used to attach module clamps, roof attachments, and other parts to the rail. To use a Quickstone, first insert a bolt through the part to be attached to the rail, and then thread a Quickstone onto the end of the bolt. Tighten the bolt until the bottom threads are just flush with the bottom of the

Quickstone. Insert the resulting assembly into the rail channel and tighten the bolt another 2 to 3 turns. The assembly will still move freely along the rail channel, but will not fall out of the rail. Move the assembly to its desired final position, and fasten firmly in place by torquing bolt to 8 Nm.

## 2. INSTALLATION

### 7. Connecting rail to roof attachments

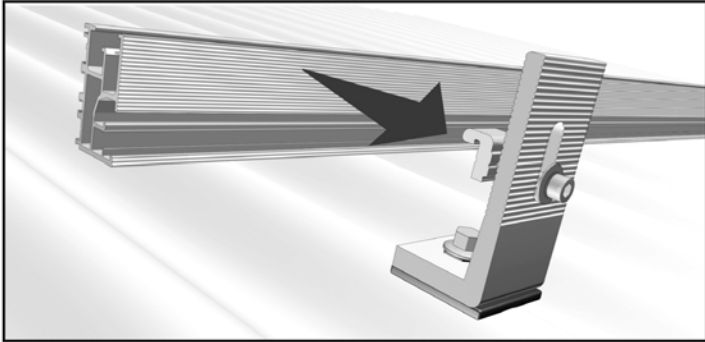

Attach rail to roof attachments (L-bracket shown) using bolts, washers, and Quickstones as shown. Make sure ridged rail surface faces ridged surface of roof attachments. When installing rows composed of different rail lengths, always begin rows with shortest rail length. Tighten bolts 2 to 3 turns.

### 8. Connecting rail to roof attachments

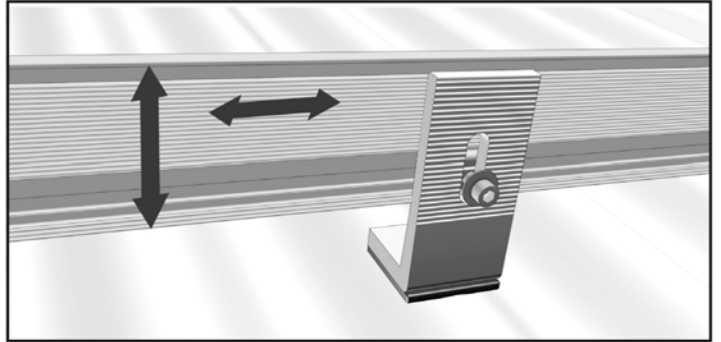

Note that rail can be adjusted horizontally along the rail channel and vertically within the roof attachment slot (L-bracket shown) when bolts are tightened only 2 to 3 turns. Additional vertical adjustment is possible using extension plates. Vertical adjustment on hanger bolt attachments is accomplished by varying L-bracket position along hanger bolt thread.

### 9. Connecting rail to roof attachments

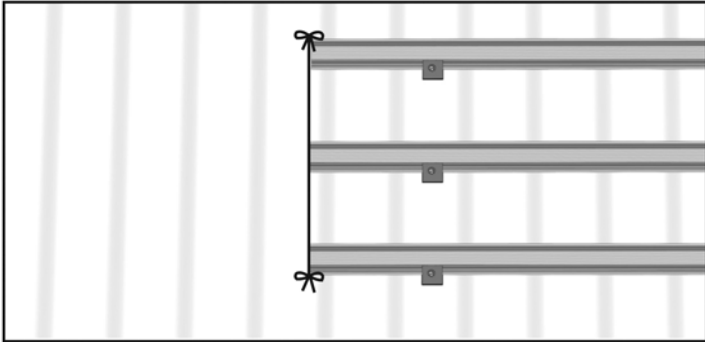

Align rails using string or other guide as appropriate. Once rails are in position, torque bolts to 8 Nm.

### 10. Connecting multiple rails using the splice

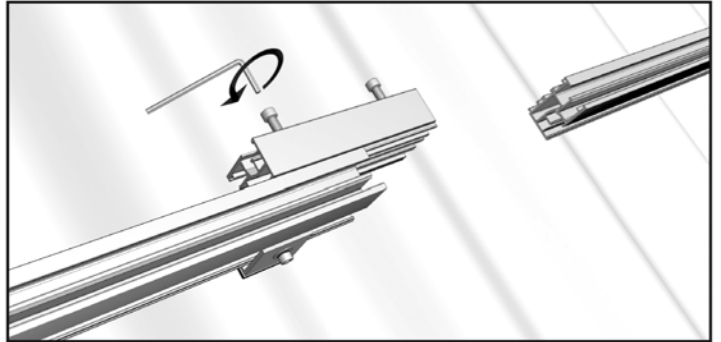

Join rail segments by sliding splice onto rear side (opposite ridged surface) of first rail segment until end of rail reaches midpoint of splice. Torque first bolt adjacent to rail to 8 Nm.

### 11. Connecting multiple rails using the splice

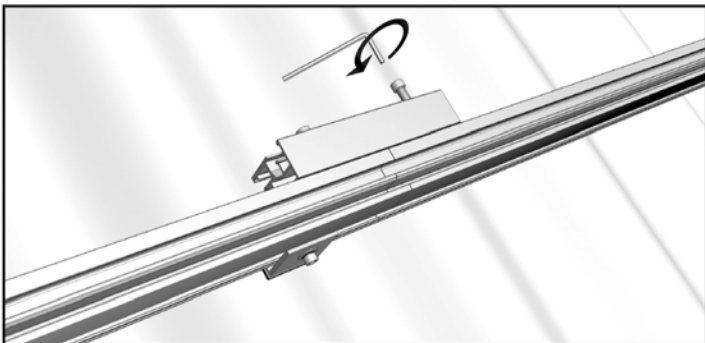

Slide second rail into splice, but leave  $\approx 5$  mm expansion gap between first and second rails. Torque second bolt to 4 Nm. If using Telescoping, see page 8 T1 to T4.

### 12. Anti-slip protection during installation

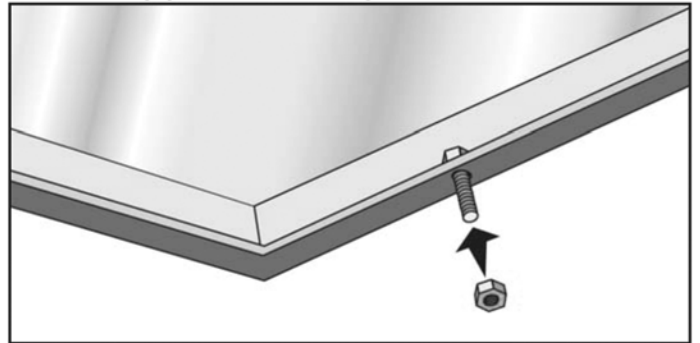

Before fitting the modules, provide the modules of the bottom row with anti-slip protection. To do this, fit M6 x 20 bolts (with the shaft pointing downwards) with M6 nuts into the modules' lower securing holes. If installing large modules (e.g. ASE250), M8 x 20 bolts are used.

---

## 2. INSTALLATION

---

### 13. Installing module end clamps

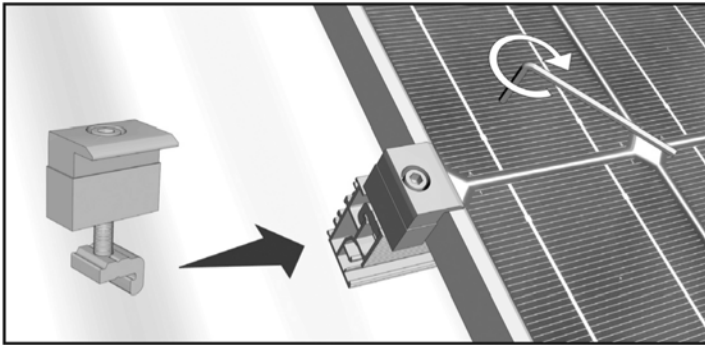

Drop Quickstone portion of end clamp assembly into rail channel and position end clamp firmly against module frame. Torque bolt to 8 Nm.

### 14. Installing module end clamps

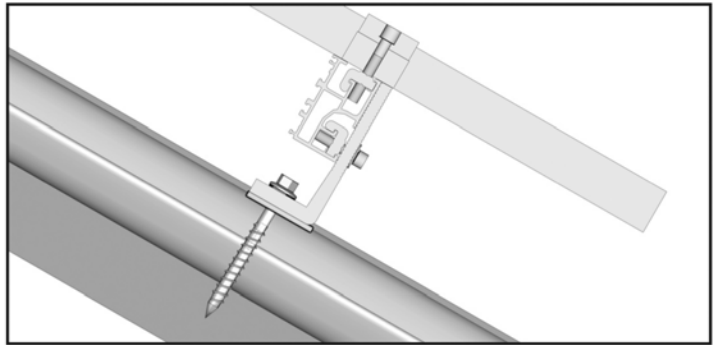

Cross section of rail, Quickstone, and module end clamp when installation has been performed correctly.

### 15. Installing inter-module clamps

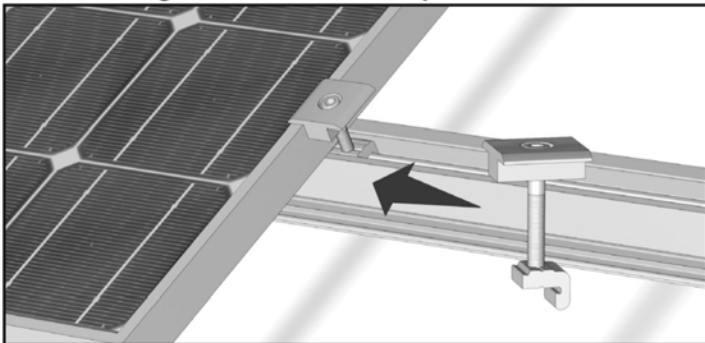

Drop Quickstone portion of inter-module clamp assembly into rail channel and position clamp firmly against first module frame. Tighten bolt 2 to 3 turns.

### 16. Installing inter-module clamps

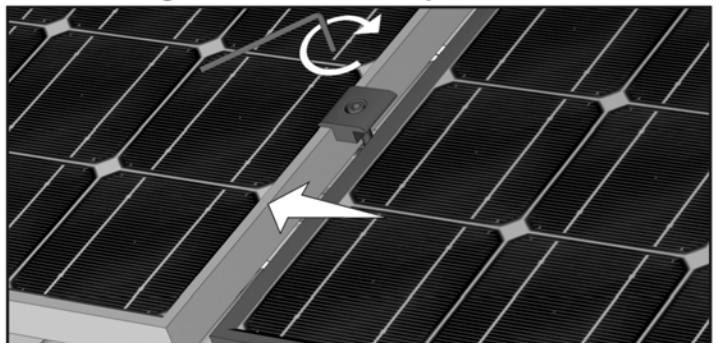

Slide second module firmly into place against inter-module clamp, and torque bolt to 8 Nm.

### 17. Installing adjacent row of modules

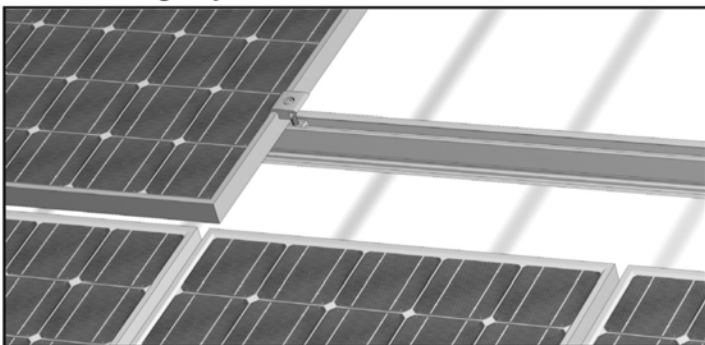

Place first module of next row in alignment with corresponding module of adjacent row. For aesthetic reasons, maintain regular vertical separation between module rows. Inter-module clamps or other temporary spacers can be used to maintain vertical separation between module rows. Continue installing modules as described above until installation is complete.

### 3. TELESCOPIC RAIL INSTALLATION

T1.

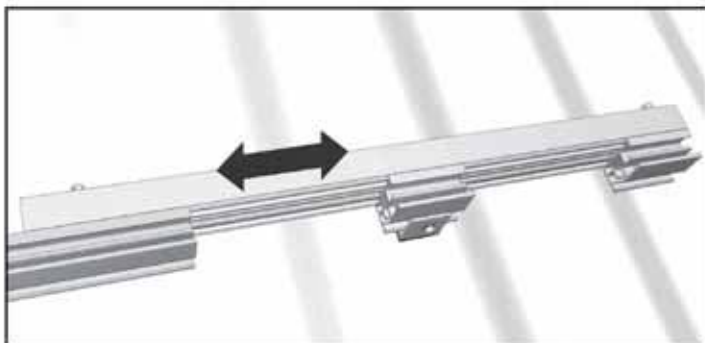

Fasten any remaining roof attachments (L-bracket shown) to telescopic rail using moveable rail element. Tighten bolt on roof attachment to 8 Nm.

T2.



Telescoping enables adjustability at row ends and eliminates the need to custom cut rails to length. Insert telescopic element into the end of the rail. Leave allen bolt at the end loose, allowing the telescopic rail to slide until final module is attached to row.

T3.

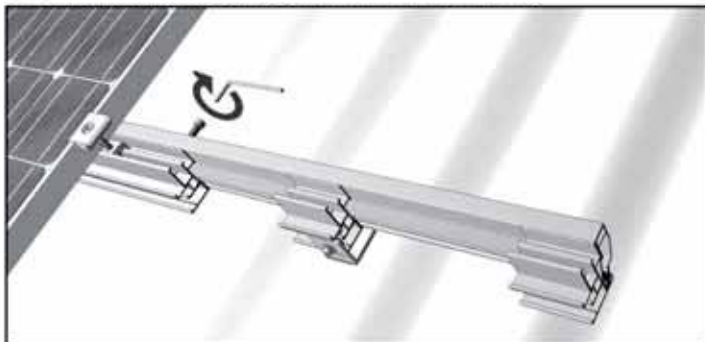

Position telescopic rail such that there is sufficient room for last module, last inter-module clamp, and end clamp. Typical spacing from next to last module to end of telescopic rail is module width +43mm. When in desired position, tighten allen bolt at telescopic rail end to 8 Nm.

T4.

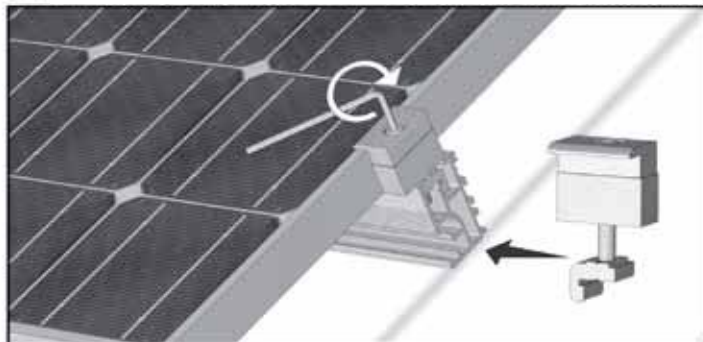

Place last module in row onto rails. Drop Quickstone portion of end clamp assembly into end of telescopic rail and slide clamp firmly against module frame. Tighten bolts on end clamp and inter-module clamp to 8 Nm.

## 4. OVERVIEW OF SYSTEM COMPONENTS

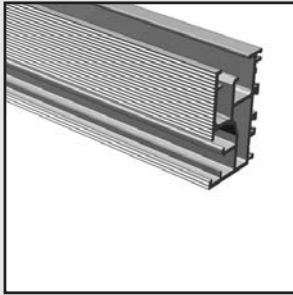

Rail

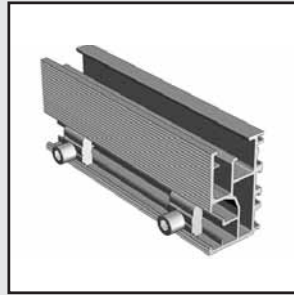

Splice

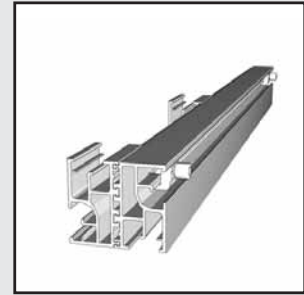

Telescoping (optional)

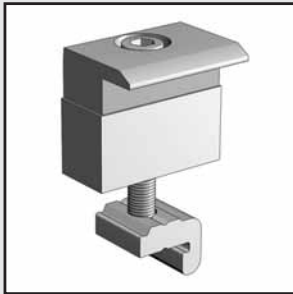

Module end clamp with Quickstone

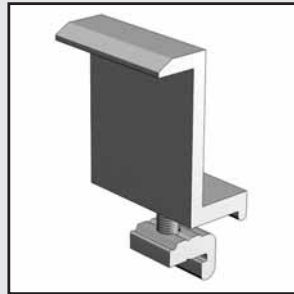

Module end clamp with Quickstone



Inter-module clamp with Quickstone

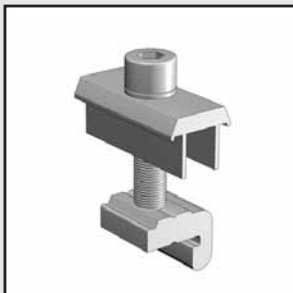

Sanyo clamp with Quickstone

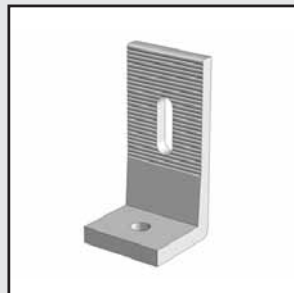

L-bracket

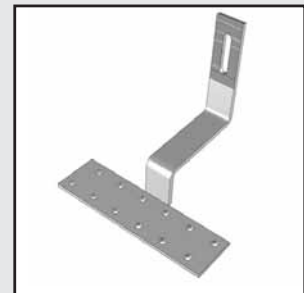

Double roman tile roof hook

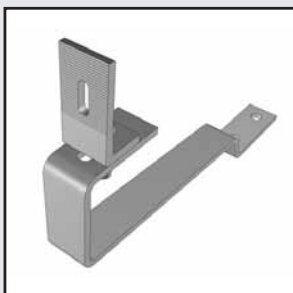

Flat tile roof hook



Slate roof hook

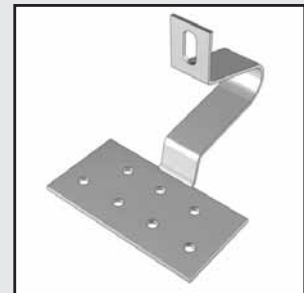

Heavy snow roof hook



Hanger bolt



Hex head Tek-screw and EDPM washer

---

## 4. GENERAL COMPANY/MANUFACTURER INFORMATION

---

### Ten Year Limited Product Warranty

Conergy AG (“Conergy”) warrants that the product(s) and parts (“Product”) sold to the original purchaser (“Purchaser”) shall perform in accordance with Conergy’s published specifications for such Product. If any failure to conform to the warranty is reported to Conergy in writing within ten (10) years after the date of receipt of the Product by Purchaser, then Conergy, upon being satisfied of the existence of such non-conformity, shall correct the same by repairing or replacing the Product, or any part thereof, at Conergy’s sole discretion. Such repair or replacement shall completely satisfy and discharge all of Conergy’s liability with respect to this Limited Warranty. If, however, Conergy is unable to correct such non-conformity by repair or by delivering replacement Product, for any reason, Conergy shall return to Purchaser the purchase price for the Product upon Conergy’s receipt of the non-conforming Product.

This Warranty does not cover damage to the Product that occurs during its shipment, storage, or installation. This Warranty shall be VOID if installation of the Product is not performed in accordance with the SunTop III Installation Manual, or if the Product has been modified, repaired, or reworked in a manner not previously authorized in writing by Conergy AG, or if the Product is installed in an environment for which it was not designed. Under no circumstances shall Conergy, whether by way of contribution, indemnification or otherwise, be liable to Purchaser, any user of the Product, or any other person for punitive, special, incidental, contingent, indirect or consequential damages arising out of or related to installation, use or any aspect of the Product under any circumstances and regardless of whether such claim for damages is based upon delays in delivery, breach of warranty or other breach of contract, strict liability, negligence, or any other theory now known or hereinafter adopted by legislation or by any court. Manufacturers of related items, such as PV modules and flashings, may provide written warranties of their own. Conergy’s Limited Warranty covers only its Product, and not any related items. The warranty and limitations set forth in this section shall apply not only to the original Product but also to any replacement Product provided or services rendered in the course of repairing or replacing any such Product. The liability of Conergy hereunder is expressly limited to repair or replacement of non-conforming Product which has been returned, at Purchaser’s risk and expense, to Conergy, or the repayment of the purchase price, as the case may be. **THIS LIMITED WARRANTY SHALL BE IN LIEU OF ALL OTHER WARRANTIES, AND ALL OTHER WARRANTIES, EXPRESS OR IMPLIED, INCLUDING THE WARRANTIES OF MERCHANTABILITY AND FITNESS FOR PURPOSE, ARE EXCLUDED.**



**superiorsolar**  
hot water | solar power | pool heating

Unit 2/10  
Enterprise Close  
West Gosford  
2250  
tel : 4323 9050

**For technical questions, please contact us:**

**[www.conergy.com.au](http://www.conergy.com.au)**

**Ph: 1300 551 303**

Subject to technical changes without notice  
2007 © Conergy

Printed on  
100% recycled paper