



AURORA[®]

Photovoltaic Inverters

INSTALLATION AND OPERATOR'S MANUAL

Model number: PVI-2000-OUTD-AU

Rev. 1.0

REVISION TABLE

Document Revision	Author	Date	✓ Change description
1.0	Gianluca Pieralli	27/10/2008	✓ First release of the document



SAVE THESE INSTRUCTIONS!



IMPORTANT SAFETY INSTRUCTIONS

POWER-ONE: Reproduction and disclosure, even partially, of the contents of this manual are strictly forbidden without prior authorization of Power-One.

IMPORTANT SAFETY INSTRUCTIONS

This manual contains important safety and operational instructions that must be accurately understood and followed during the installation and maintenance of the equipment.

To reduce the risk of electrical shock hazards, and to make sure the equipment is safely installed and commissioned, special safety symbols are used in this manual to highlight potential safety risks and important safety information. The symbols are:



WARNING: the paragraphs highlighted by this symbol contain processes and instructions that must be absolutely understood and followed to avoid potential danger to people.



NOTE: the paragraphs highlighted by this symbol contain processes and instructions that must be rigorously understood and followed to avoid potential damage to the equipment and negative results.

The equipment is provided with several labels, some of them with a yellow background, which are related to safety issues.

Make sure to read the labels and fully understand them before installing the equipment.

The labels use the following symbols:

	Equipment grounding conductor (Main grounding protective earth, PE)
	Alternate Current (Ac) value
	Direct Current (Dc) value
	Phase
	Grounding (Earth)

USEFUL INFORMATION ON SAFETY STANDARDS

FOREWORD

- The installation of AURORA must be performed in full compliance with national and local standards and regulations.
- AURORA has no internal user serviceable parts other than fuses.
For any maintenance or repair please contact the nearest authorized repair centre. Please contact your reseller if you need to know the nearest authorised repair centre.
- Read and understand all the instructions contained in this manual and become familiar with the safety symbols in the relevant paragraphs before you install and commission the equipment.
- The connection to the distribution grid must be done only after receiving approval from the distribution utility as required by national and state interconnection regulations, and can be done only by qualified personnel.
- Cover the photovoltaic panels with dark opaque sheets before they are connected to avoid any chance of high voltages appearing at the connecting wire terminations.

GENERAL

During inverter operation, some internal parts can be energised, in some cases, internal parts can move or rotate and some surfaces can be hot.

Unauthorised removal of the necessary protections, improper use, incorrect installation or incorrect operation may lead to serious damage to people and objects.

All transport, installation and start-up, as well as maintenance operations, shall be carried out by skilled and trained personnel (all national regulations on accidents prevention and electrical safety shall be complied with!!!).

Only qualified and trained people have skills for the assembling, start-up and operation of the product, as well as the necessary requirements and qualifications to perform such operations.

INSTALLATION

All equipment shall be installed according to the instructions and specifications mentioned in the corresponding documents.

In particular, during transport and handling, parts shall not be bent and/or the insulation distances shall not be changed. There should be no contact between electronic parts and connection terminals.

Electrical parts must not be mechanically damaged or destroyed (potential health risk).

ELECTRICAL CONNECTION

The Aurora inverter should be installed in compliance with all prevailing local and national regulations

Electrical connections shall be carried out in accordance with the applicable regulations, such as conductor sizing, over-current protection devices and grounding connection.

OPERATION

Systems with inverters shall be installed in accordance with applicable electrical safety and personnel safety requirements. After the inverter has been disconnected from the both input power and output power connections allow the internal capacitors to discharge before working on the equipment

Comply with all corresponding marks and symbols present on each device. During operation, make sure that all covers and doors are closed.

MAINTENANCE AND SERVICE

Comply with manufacturer's recommendations.

SAVE ALL DOCUMENTS IN A SAFE PLACE!

PVI-2000-OUTD-AU

This document applies to the above-mentioned inverters, only

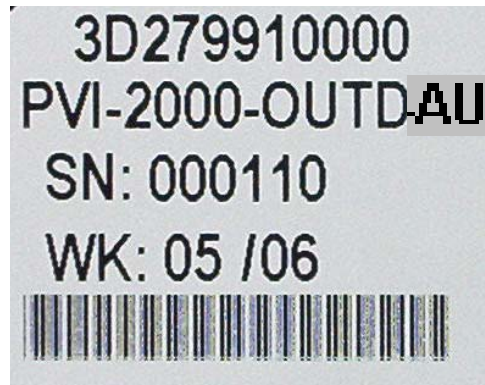

Fig.1 Product label

The identification plate present on the inverter includes the following data:

- 1) Manufacturer Part Number
- 2) Model Number
- 3) Serial Number
- 4) Production Week/Year

CONTENTS:

1	FOREWARD	10
1.1	PHOTOVOLTAIC ENERGY	10
2	SYSTEM DESCRIPTION.....	11
2.1	MAIN ELEMENTS OF A PV SYSTEM: “STRINGS AND ARRAYS”	12
2.2	DATA TRANSMISSION AND CHECK	14
2.3	AURORA TECHNICAL DESCRIPTION	14
2.4	PROTECTIVE DEVICES	16
2.4.1	<i>Anti-Islanding</i>	16
2.4.2	<i>Panel Ground Fault</i>	16
2.4.3	<i>Further Protective Devices</i>	17
3	INSTALLATION	18
3.1	PACKAGE INSPECTION	18
3.2	PACKAGE CHECK LIST.....	19
3.3	CHOOSING INSTALLATION LOCATION	20
3.4	WALL MOUNTING	21
3.5	PRELIMINARIES TO ELECTRICAL CONNECTIONS	24
3.6	ELECTRICAL CONNECTIONS	27
3.7	ACCESS TO THE TERMINAL BLOCKS BY REMOVING THE RIGHT SIDE PANEL	29
4	START-UP	30
5	MONITORING AND DATA TRANSMISSION.....	31
5.1	USER INTERFACE MODE	31
5.2	AVAILABLE DATA	33
5.2.1	<i>Real time data</i>	33
5.2.2	<i>Internally Logged Data</i>	34
5.3	LED INDICATORS	35
5.4	MESSAGES AND ERROR CODES.....	40

5.5	LCD DISPLAY.....	43
6	DATA CHECK AND COMMUNICATION.....	49
6.1	RS-485 SERIAL LINK.....	49
6.2	ADDRESS SELECTION	52
6.3	BAUD RATE SETTING	53
6.4	MEASUREMENT ACCURACY.....	55
7	TROUBLESHOOTING.....	56
8	TECHNICAL FEATURES.....	58
8.1	INPUT VALUES	58
8.2	OUTPUT VALUES	61
8.3	GRID PROTECTION CHARACTERISTICS	62
8.4	GENERAL CHARACTERISTICS	62
8.5	POWER DERATING	63

1 FOREWARD

This document contains a technical description of the AURORA photovoltaic inverter so as to provide the installer and user all the necessary information about installation, operation and use of AURORA.

1.1 PHOTOVOLTAIC ENERGY

Industrialised countries (greater energy consumers) have been experimenting with energy-saving methods and reducing pollutant levels. This may be possible through a shrewd and rational consumption of well-known resources, and also by looking for new forms of clean and inexhaustible energy.

Renewable sources of energy are fundamental to solving this problem. Under these circumstances, solar energy exploitation to generate electrical (photovoltaic) energy is becoming more and more important worldwide.

Photovoltaic energy is, in any case, of great advantage to the environment because the radiated energy we receive from the sun is transformed directly into electrical energy without any combustion process and without producing any pollution.

2 SYSTEM DESCRIPTION

AURORA is an inverter that exports energy to the electrical power distribution grid. Photovoltaic panels transform the solar radiation into electrical energy in the form of direct (Dc) current (through a photovoltaic field, also known as PV generator); In order to utilise this energy and feed it back to the distribution grid, this energy shall be turned into alternating (Ac) current. AURORA does this conversion, also known as Dc to Ac inversion, in a very efficient way, without using rotating parts but only static power electronic devices.

When used in parallel with the grid, the alternate current generated by the inverter is directly fed to the domestic distribution circuit, which in turn is also connected to the public power distribution grid.

The solar energy system can thus feed power to all the connected devices, such as lighting devices, household appliances, etc.

If the energy generated by the photovoltaic system is not enough, the energy necessary to ensure the standard operation of the connected devices is drawn from the public power distribution grid. If the energy produced exceeds that used, the difference is directly fed to the grid, thus becoming available to other users.

According to national and local standards and regulations the produced energy can be sold to the grid or credited to the user for future consumption.

2.1 Main Elements of a PV System: “STRINGS and ARRAYS”

The so-called “string” technology has been developed in order to reduce the installation costs of a photovoltaic system as much as possible. These costs are mainly related to the wiring operations on the Dc side of the inverter and the consequent distribution on the Ac side.

A photovoltaic PANEL is composed of many photovoltaic cells assembled on the same mount. A STRING is composed of a certain number of panels electrically connected in series. An ARRAY is composed of one or more strings connected in parallel.

Larger photovoltaic systems can be composed of a certain number of arrays, connected to one or more AURORA inverters. By maximizing the number of panels in series per string, the cost and complexity of the system wiring can be reduced.

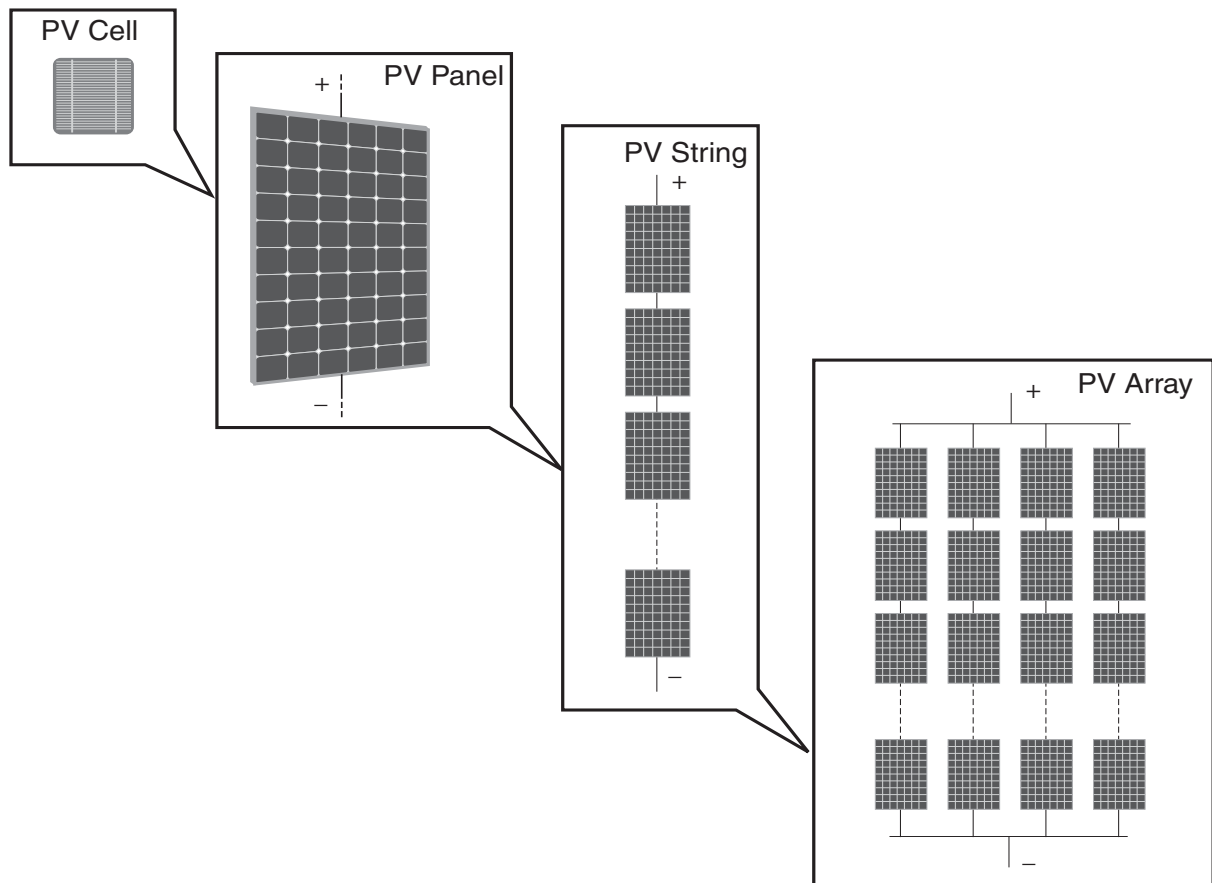

✓ Fig.2 Array Composition

Array voltage value shall be within an acceptable range for the inverter. Please refer to the technical data for the AURORA for details on the Dc operating voltage range.



WARNING: String voltage shall not exceed 600 Vdc for any reason, to prevent any damage to the equipment

NOTE: The minimum required input voltage for start the initial grid connection sequence is 200Vdc.

When Aurora is connected, it will export energy on the grid since the input range will remain between 90Vdc and 580Vdc.

The total current of an array must also be within the capability limits of the inverter. The 2000W model of AURORA is capable of handling a single array and the maximum input current can be 10Adc.

In case the photovoltaic system exceeds the capabilities of a single AURORA inverter, additional inverters can be added to the system, each connected to a suitable section of the photovoltaic field on the Dc side, and to the grid on the Ac side.

Each AURORA inverter will work independently from the others and will push to the grid the maximum power available from its own section of the photovoltaic panels.

The actual decisions on the way the photovoltaic system is structured and wired depend on a number of factors and considerations, such as type and model of panels, available area, location, energy targets, as well as on good design practices.

Power-One provides a system configuration tool on its website (www.power-one.com) that can assist in modelling the system.

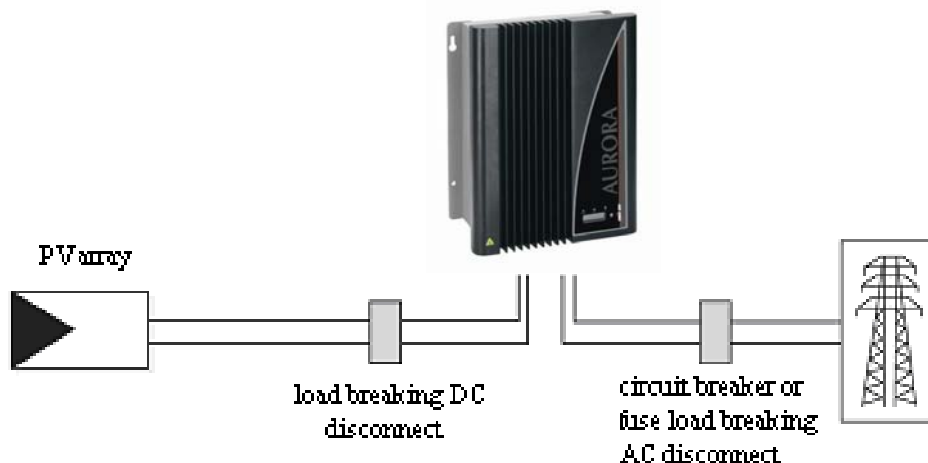

Fig.3 Simplified diagram of a photovoltaic system

2.2 Data transmission and check

In case multiple inverters are used, they can be monitored remotely by using an advanced communication system based on the RS485 serial interface or on the Power Line Modem (PLM) technology. For further information, refer to the corresponding sections of this manual.

2.3 AURORA Technical Description

Figure 4 shows the AURORA block diagram. The main blocks are given by the input Dc-Dc converters (also known as “booster”) and the output inverter. Both the Dc-Dc converters and the output inverter work at high switching frequency to minimize size and weight.

This model of AURORA is transformer-less, that means that there is no galvanic isolation between input and output. This allows an increase in the inverter efficiency. AURORA, on the other hand, is equipped with all the protection needed to operate safely and to comply with existing safety regulations even without an isolation transformer, as described in the paragraph regarding protective devices.

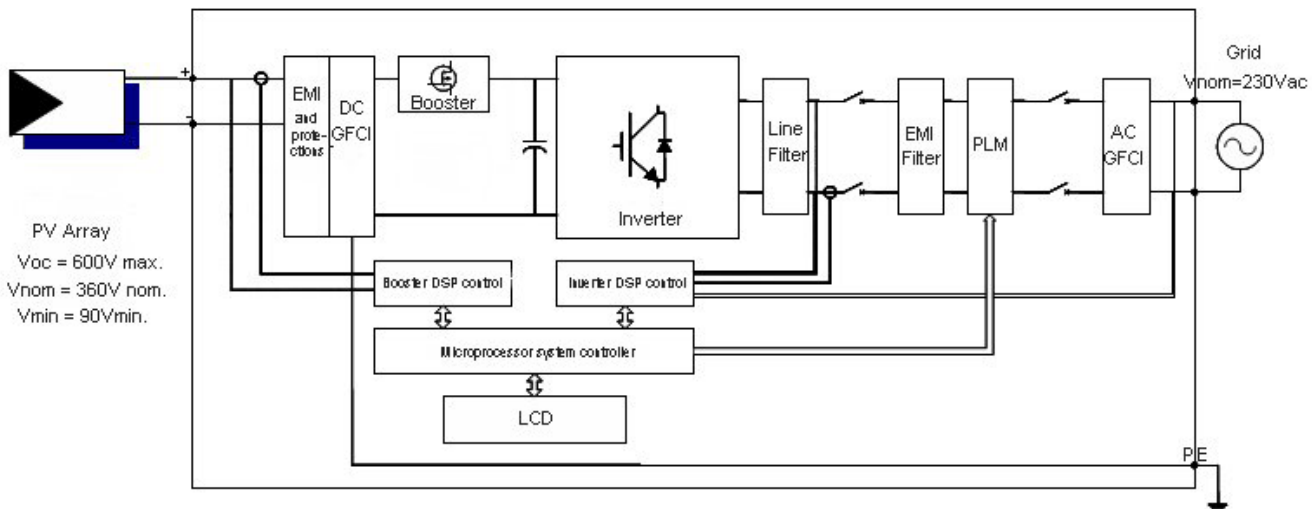

Fig.4 AURORA block diagram

The block diagram shows the model AURORA PVI-2000-OUTD.

Thanks to its high efficiency and its widely dimensioned thermal dissipation system, this inverter guarantees maximum power operation over a wide ambient temperature range.

The inverter is controlled by two independent Digital Signal Processors (DSP) and a central microprocessor.

The connection to the electrical grid is, therefore, controlled by two independent computers, in compliance with electrical standards, power system standards and safety standards.

the AURORA operative system communicates with the relative components to carry out data analysis.

All this guarantees an optimal operation of the whole system and a very high performance in every insulation and load situation, always in compliance with the relative standards and regulations.

2.4 Protective devices

2.4.1 Anti-Islanding

The Aurora inverter will automatically disconnect from the utility grid when the utility grid is out of range or when the inverter shuts down due to a fault condition, in order to guarantee protection for persons operating on the utility grid, in compliance with the national standards.

AURORA PVI-2000-OUTD is equipped with an advanced Anti-Islanding protection certified according to the following standards:

- AS4777.3-2005

2.4.2 Panel Ground Fault

This version of Aurora is designed for connection to floating Photovoltaic arrays only, with the positive and negative terminals from the panels are not connected to the Ground (the metallic support of the panel instead shall be connected to safety Ground in accordance with existing electrical safety regulations). An advanced ground fault protection circuit continuously monitors the ground connection and shuts down AURORA in case a ground fault is detected and indicates the ground fault condition by means of a red LED on the front panel. A terminal for the equipment grounding conductor is provided in the AURORA inverter. For further information, please see section 3.5.3.

2.4.3 Further Protective Devices

AURORA is equipped with additional protections to guarantee safe operation under all circumstances. The protections include:

- Continuous monitoring of the grid voltage to ensure the frequency and voltage values are within the proper operational limits;
- Control of the internal temperatures to automatically limit power when needed to make sure the unit does not overheat (heat-sink temperature $\leq 70^{\circ}\text{C}$ [158°F]).

The many AURORA control devices determine a redundant structure to guarantee safe operating use.

3 INSTALLATION



WARNING: The electrical installation of AURORA must be made in accordance with the local and national electrical standards and regulations.



WARNING: The connection of AURORA to the electrical distribution grid must be performed only after receiving authorization from the utility that operates the grid.

3.1 Package inspection



NOTE: The distributor presented your AURORA to the delivering carrier securely packed and in perfect conditions. Upon acceptance of the package from the distributor, the delivering carrier assumes responsibility for its safe arrival to you. Despite of the attention paid by carrier in handling it, sometimes the package and its contents might be damaged.

Please, carry out the following checks:

- Examine the shipping box for any visible damage: punctures, dents or any other signs of possible internal damage;
- Describe any damage or shortage on the receiving documents and have the carrier sign their full name;
- Open the shipping box and inspect the contents for internal damage. While unpacking, be careful not to discard any equipment, parts or manuals. If any damage is detected, call the delivering carrier to determine the appropriate action. They may require an inspection. Save all shipping material for the inspector to see!

If the inspection reveals damage to the inverter call your retailer, or authorized distributor. They will determine if the equipment should be returned for repair. They will also provide instructions on how to get the equipment repaired;

- It is your responsibility to file a claim with the delivery carrier. Failure to properly file a claim for shipping damages may void warranty service for any physical damages later reported for repair;
- Save AURORA original packaging, as it will have to be used in case the equipment has to be shipped out for repairs.

3.2 Package Check List

Description	Quantity (No.)
AURORA Photovoltaic Inverter	1
Bag containing a wall fixing kit composed of 4 stainless steel screws, 4 blocks and a TX20 tap wrench, and a connector kit, composed of 1 signal wire gland, a double-hole seal, 1 positive Multicontact connector cap and 1 negative connector cap, 1 Binder connector counterpart.	1
Installation drawing	1
Copy of this manual	1
Certificate of warranty	1
CD-Rom with communication software	1

3.3 Choosing installation location

The location for the installation of AURORA should be selected in accordance to the following recommendations:

- AURORA should be placed at a suitable height from the ground to allow easy reading of the front display.
- Leave enough room around the unit to allow easy installation and maintenance (Fig 5).
- Choose a location sheltered from sun radiation and able to provide some ventilation.
- The screw and tabs for wall mounting need to be chosen according to the wall construction material (stone, full bricks, holed bricks, etc).



WARNING: The metal surface in the back of AURORA could reach high operating temperatures (**up to 70°C**). Avoid contact of the surface with materials that are flammable or sensitive to high temperature (wallpaper, fabrics, wood, etc.)

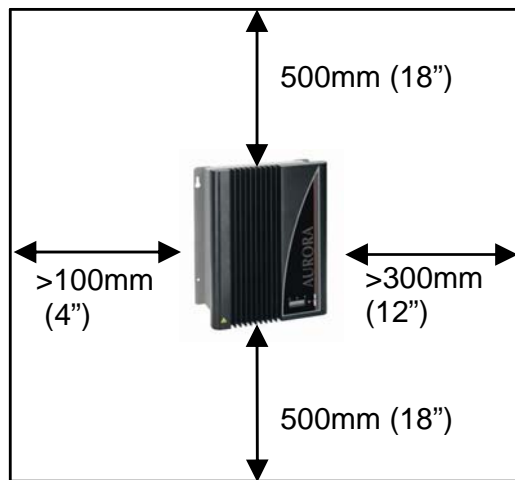

Fig.5 Installation location

3.4 Wall Mounting

AURORA should be mounted in a vertical position as shown in figure 7.



NOTE: AURORA ratings are based on a vertical mounting position. Although it is possible to mount AURORA in a tilted position, the thermal performance in that case may be de-rated. In any case avoid mounting AURORA with the front plate rotated, always make sure that the fins of the front heatsink are vertical.

To facilitate wall mounting a reference drawing is provided in the package (Fig.6). Use the drawing to locate the holes on the wall. A set of standard expansion stainless steel screws is included in the package for use in mounting the AURORA to a masonry wall. In case of different materials make sure to select the proper mounting hardware. Always use stainless steel mounting hardware, if the supplied hardware is not used.

The clearance hole in the mount bracket is 8 mm.

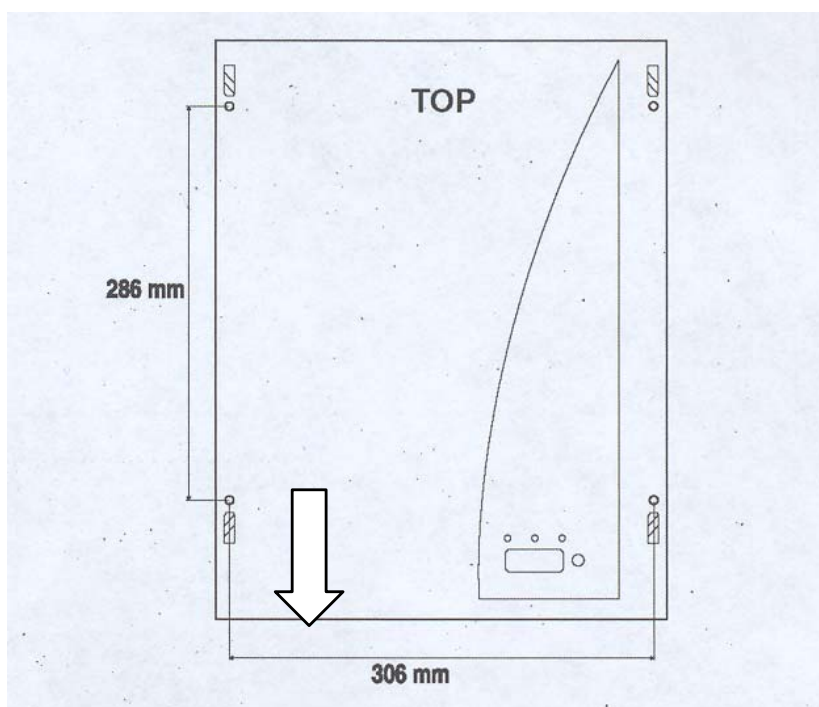

Fig. 6 Wall mounting diagram

Install the expansion screws in the wall so that the head of the screws is about 4mm (~1/6") from the wall surface. Then hang AURORA on the wall by fitting the screw heads in the mounting slots as shown in Fig.7, and secure the screws.

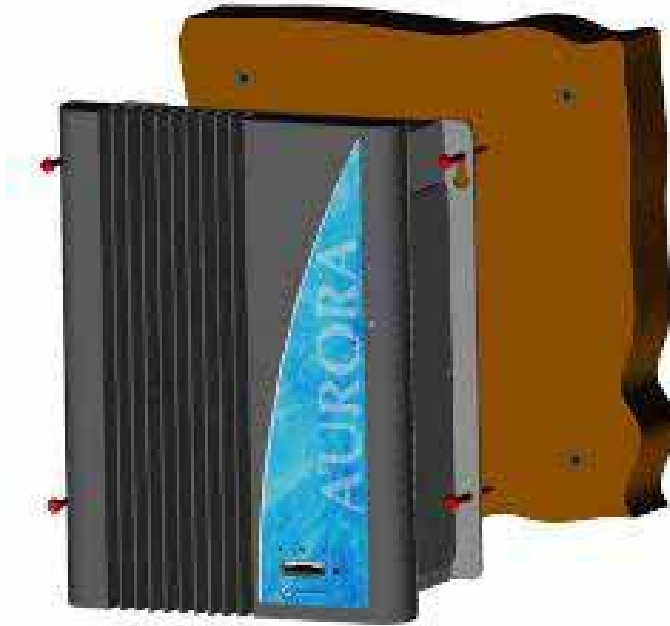

Fig.7 AURORA wall mounting

It is possible to mount AURORA in a tilted position. In that case the thermal dissipation will not be optimized and the unit may derate the maximum output power at ambient temperatures below 40°C (see Fig. 9).



NOTE: In case of installation of several units, Power-One recommends not to install them in parallel, superimposed, rows. In fact the heat generated by the bottom rows will get the ambient temperature of the upper inverters to increase. At ambient temperatures higher than + 40 °C an output power derating may occur on the top units.



Fig.8 Aurora, recommended assembling

It is recommended that the unit is not placed in direct sunlight.



WARNING: During operation, inverter surface can reach very high temperatures.
DO NOT touch inverter surface to prevent the risk of burns.

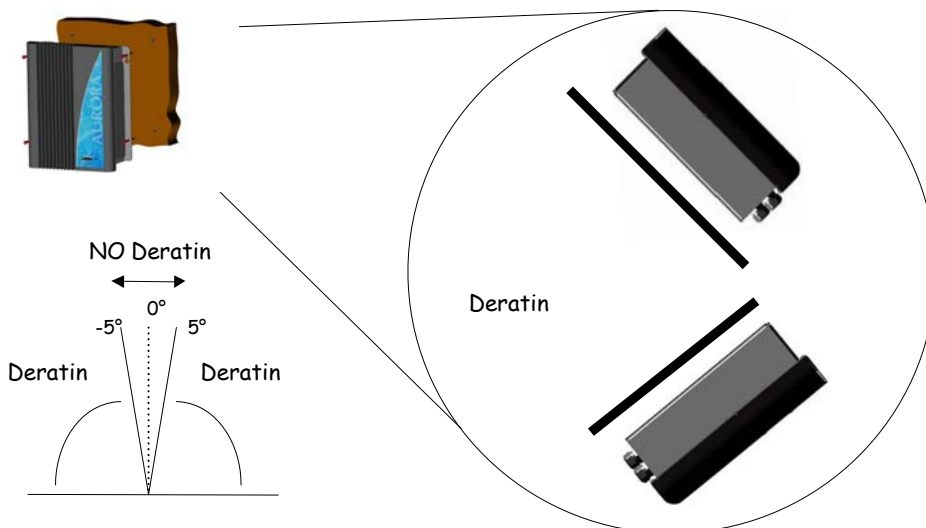

Fig.9 Inverter tilted mounting

3.5 Preliminaries to Electrical Connections



WARNING: The electrical connections can be done only after securing AURORA to the wall.



WARNING: The connection of AURORA to the electrical distribution grid must be performed only by skilled operators and after having received authorization from the utility that operates the grid.



WARNING: For further details on each installation step, carefully read and follow the instructions of this section (and sub-sections) step-by-step, as well as all safety warnings. Any operation non-complying with the instructions below can lead to operator/installer hazards and to equipment damage.



WARNING: Always respect the nominal ratings of voltage and current defined in chapter 8 (Technical Features) when designing your system. In particular, regarding the photovoltaic system:

- Maximum Dc array input voltage for each MPPT circuit: 600Vdc in any condition.
- Maximum Dc array input current for MPPT circuit: 10A_{dc} in any condition.



WARNING: Verify the national regulations and the local standards, to make sure that your installation design complies to them.



WARNING: carefully cover the entire surface of the photovoltaic panels with an opaque material (possibly black) to protect them from sun radiation.



NOTE: According to the typical assembly diagram (see Fig.8) each array must be connected to Dc disconnect. An AC disconnecting mean provided with fuses or an over-current protection must be used to connect AURORA to the grid. Although the fuses are not mandatory, should you choose to use a Power-One-approved over-current protection, we recommend insetting them in the system.

Recommended ratings for the Ac over-current protection device is maximum 10A, 240V.

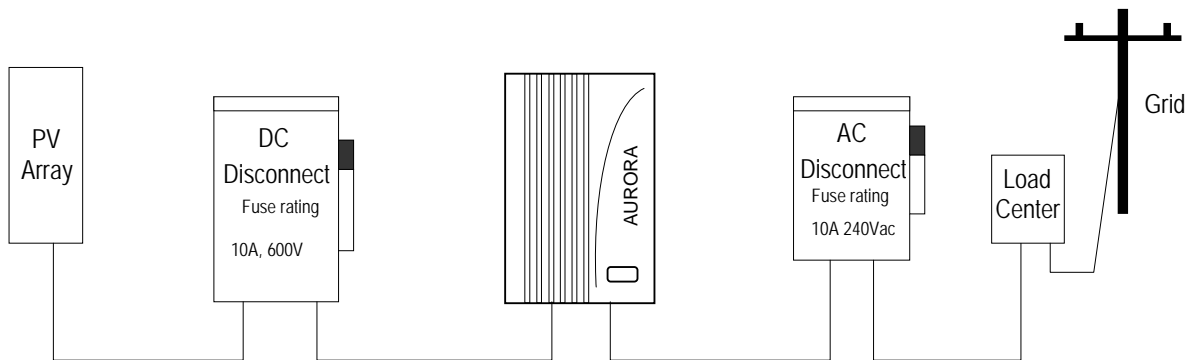

✓ Fig.10 General wiring diagram



WARNING: always open the AC disconnect breaker to disconnect AURORA from the grid before opening the DC disconnect.



WARNING: All power wires connecting AURORA must have a section of at least 14 AWG (2.5mm²) and must be able to operate at temperature of at least 90 °C.

We recommend using the following types of wires:

For connecting the panels: FG7 (0)R unipolar wire, or H07RNF wire with sections 2.5; 4; or 6 mm² with an external diameter of max. 8,9mm.

For connecting to the grid: FG7(0)R tripolar wire with a section of 2.5 or 4 mm² with an external diameter of max 16,2mm.

At the bottom of the inverter, from left to right, (Fig. 11) there are:

- 1 watertight cap. This cap can be replaced by the PG16,5 cable gland supplied with the inverter to route the signal cable for RS485 serial link.
- 1 Binder connector for connection to the grid
- 1 pair of Multicontact connectors, for the connection of the PV array (IN1).
- 2 watertight caps seal off the "IN2" inputs (only available on PVI-3600 models)

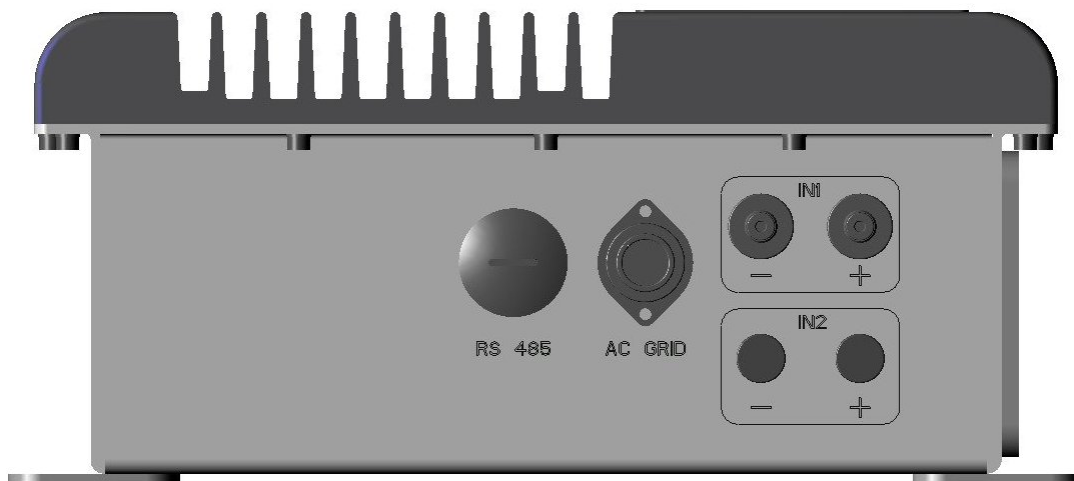

Fig.11 Connections at the bottom of the inverter



WARNING: When making the electrical connections follow this exact procedure to avoid exposure to dangerous voltages. Each step of the procedure is explained in the following paragraphs.

To disconnect AURORA always open the AC breaker first and then also the DC breaker prior to do any further operation and before removing the AC and DC connections to the inverter.

3.6 Electrical connections

Step 1/4: Open the Ac disconnect switch

Step 2/4: Open the Dc disconnect switch

Step 3/4: Connect AURORA to the Ac disconnect switch



WARNING: Use proper, low impedance wires to connect AURORA to the Ac disconnect.



WARNING: AURORA must be connected to the AC disconnect switch with a tripolar wire: a phase conductor, a neutral conductor and a yellow-green one for the earth connection (PE protection).

- 1) Lay the wire between AURORA and the Ac disconnect switch
- 2) Enter the wire in the Binder counterpart connector provided, taking care to respect the indications present on the plastic near the terminal blocks (as indicated in Fig. 11): terminal block 1 for Neutral, terminal block 2 for the line, terminal block 3 not connected, and the terminal block identified by the  symbol for the PE earth connection.
- 3) Connect the Binder connector

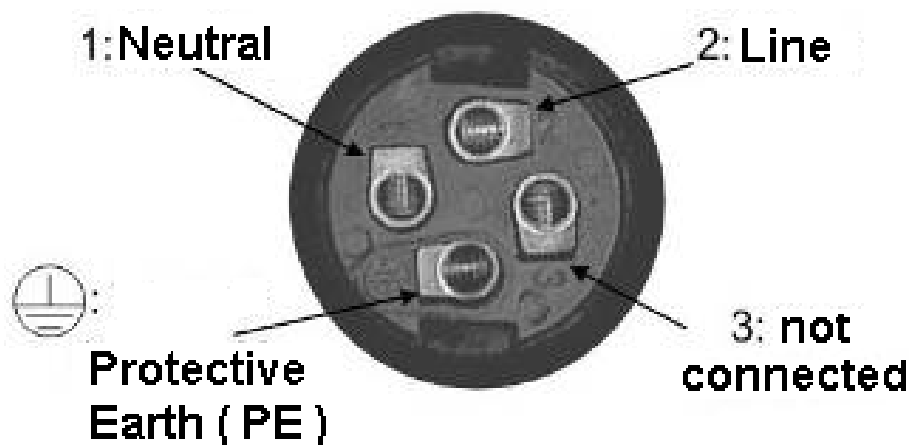

Fig. 12 Binder connector



WARNING: Pay special attention at not inverting the phase with the neutral because it could compromise the system safety and cause malfunctioning of the appliance.



NOTE: In case your system has an additional kW-hour metre installed between the Ac disconnect and AURORA, please apply the Ac connection procedure to the terminals of the metre.

Step 4/4: Connect AURORA to the Dc disconnect switches

Power-One recommends, whenever it is possible, to use two separate arrays, each with a current capacity lower than 10A_{dc}, and to connect each array to an input section of the AURORA inverter.



WARNING: Take special care to ensure the photovoltaic voltage polarity corresponds to the symbols “+” and “-” labelled on the contacts of the photovoltaic field.

Before connecting AURORA with the photovoltaic field, Power-One recommends checking, using a proper gauge, that the polarity value and the voltage value allowed between positive and negative contacts are correct.

Array connection: Follow this procedure for each array.

- 1) Mount the positive cable between AURORA and the Dc disconnect.
- 2) Secure the cable to the counterpart multicontact connector (not provided)
- 3) Connect the positive cable to AURORA
- 4) Mount the negative cable between AURORA and the Dc disconnect.
- 5) Secure the cable to the counterpart multicontact connector (not provided)
- 6) Connect the negative cable to AURORA

3.7 Access to the terminal blocks by removing the right side panel



WARNING: To avoid the risk of electric shock from energy stored in capacitors. Wait 5 minutes after disconnecting both Ac and Dc connections before opening the side panel.

To remove the side panel unscrew it using the Torx TX20 wrench supplied with the inverter kit.



Fig. 13 Removing the side panel

After operation the side panel screws shall be tightened with a torque of 1.5 Nm (13.2 in-lbs) to ensure watertight sealing.

4 START-UP



WARNING: Do not lay any object on AURORA during operation.
WARNING: do not touch the heatsink during operation, some parts could be very hot and cause serious burns.

To start up AURORA switch the external Dc disconnect on the ON position.

- 1) Switch the Ac disconnect to the ON position.
- 2) AURORA will start operating and the green LED label Power on the front panels will start blinking while the grid is checked to make sure that voltage, impedance and frequency parameters are within operating range per AS4777.3-2005 requirements. The check can last a few minutes depending on the conditions of the grid. During the check the LCD display will show a sequence of three screens, indicating:
 - Remaining time for next connection.
 - Grid voltage value and status (in or out of range)
 - Grid frequency value and status (in or out of range)
- 3) If the grid check is successfully completed the unit will perform a protective test on the unit. It's normal that the unit produces an audible sound during the test.
- 4) Then the AURORA will export to the grid and the green Power LED will be continuously lit (provided there is enough solar radiation to feed power to the grid).
- 5) If the grid check is not successful the unit repeats the check over and over again until acceptable grid parameters are found. During this procedure the green power LED keeps blinking. Measure the grid voltage and frequency and then verify the grid configuration of the unit.

5 MONITORING AND DATA TRANSMISSION

5.1 User Interface Mode



WARNING: The RS-485 wire must ensure a protection of at least 600V.

The AURORA inverter usually works automatically and is maintenance-free. When solar radiation is not high enough to provide power for export to the grid (during night time, for example) AURORA disconnects automatically, and enters the stand-by mode, waiting to start working again. The operational cycle is automatically restored as soon as the solar radiation is enough.

AURORA inverter can provide operational data in the following ways:

- LED indicators
- Operational data on the LCD display
- Data transmission on a dedicated serial RS-485 line or RS-232 line. The data can be collected by a PC or data logger equipped with a suitable RS-485 or RS-232 port. In case you use the RS-485 line, a RS-485/RS-232 AURORA serial interface converter model number PVI-RS232485 can be useful. You can also use the AURORA Easy Control (*) data logger.

(*) Please check if this accessory is available with your installer or retailer.

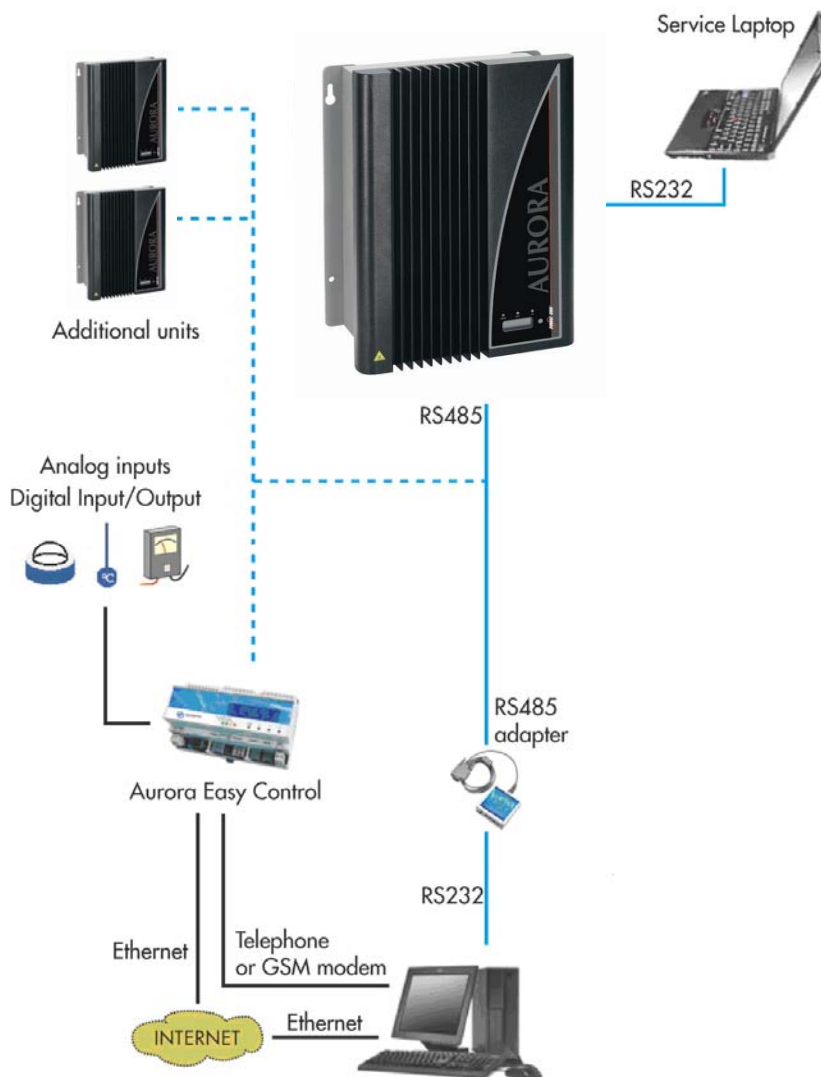

Fig.14 – Aurora data communication

5.2 Available Data

AURORA provides two sets of data that are accessed using AURORA interface software.

5.2.1 Real time data

The real time operating data can be transmitted upon request over the communication lines and is not recorded internally by the AURORA inverter. The free AURORA Communicator interface software, provided on the installation CD can be used to retrieve and store data on a PC computer (please check on www.power-one.com for updated versions).

The following data are available:

- Grid voltage
- Grid current
- Grid frequency
- Power transferred to the grid
- Voltage of PV array
- Current of PV array
- Heat sink temperature
- Serial Number Part Number
- Manufacturing week
- Firmware revision code
- Energy produced so far in the day
- Leakage Current

5.2.2 Internally Logged Data

AURORA stores internally the following data:

- Lifetime counter of grid connection time
- Lifetime counter of energy transferred to the grid
- Energy transferred to the grid every 10 seconds for the last 8640 periods of 10 seconds (which on average cover more than 2 days logged data)
- Partial counter of grid connection time (the counter start time can be reset by using the AURORA Communicator software)
- Partial counter of energy (uses the same start time of the partial time counter)
- Last 100 fault conditions with error code and time stamp
- Last 100 variations to the grid connection parameters with parameter code, new value.

The first two data of the list are displayed on the LCD and on the RS-485 interface, while all the other data can be shown by the RS-485 interface only.

5.3 LED Indicators

Above the display there are three LED indicators: one to indicate whether the inverter is operating regularly, one to signal the presence of faults and one to indicate a ground fault.

1. The green "POWER" LED indicates that AURORA is working correctly. When the unit is powered on this led is blinking while the grid is checked. If the grid parameters are within the normative limits and there is enough solar energy, the unit starts to export energy to the grid and the LED is on. If, on the other hand, the sun is too low, the LED keeps blinking and the LCD shows the message "waiting for sun."
2. The yellow "FAULT" LED indicates that AURORA has detected a fault. The type of fault will be described in the LCD display.
3. The red "GFI" (ground fault) LED indicates that AURORA has detected a ground fault in the PV system on the DC side. When this type of fault is detected, AURORA immediately disconnects from the Grid and an error message appears on the display. AURORA will remain in that status until the operator presses ESC button (4) to restart the connection sequence. If AURORA does not connect and a Ground Fault is detected again technical assistance should be contacted to review the overall system for the ground fault condition.

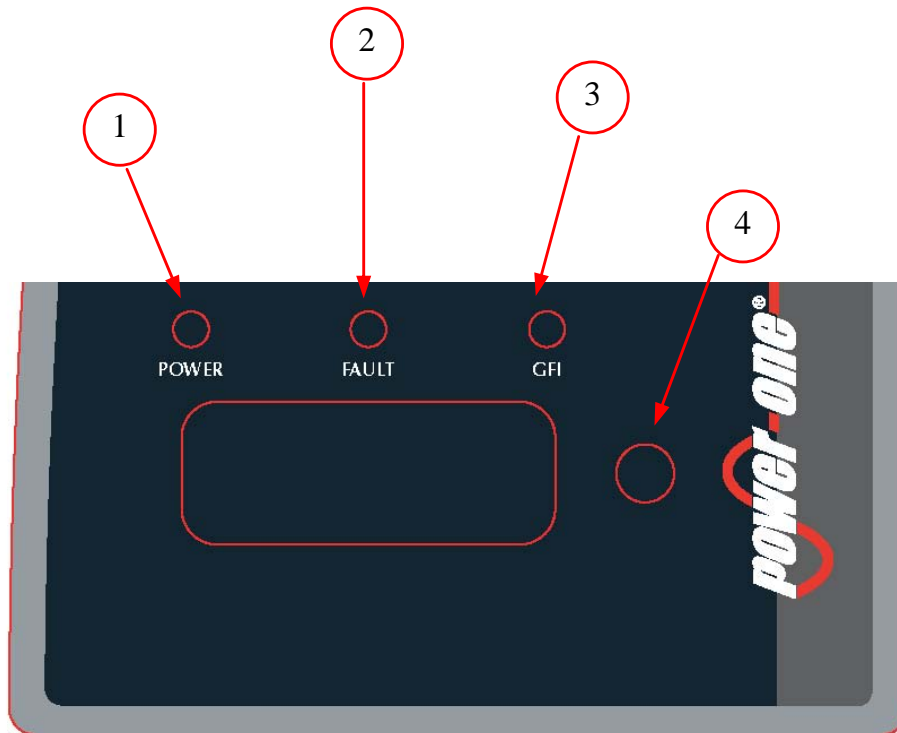

Fig.15 LED location

The following table summarize all the possible LED activation configurations related to each AURORA inverter operating status.

KEY:

- LED on
- LED flashing
- LED off
- Any of the above conditions

	LEDs Status	Operational Status	Remarks
1	green: ☒ yellow: ☒ red: ☒	Aurora self-disconnection during nighttime	Input voltage less than 90 Vdc at both inputs
2	green: ◼ yellow: ☒ red: ☒	Aurora initialization, settings loading and waiting for grid check	It is a transition status while operating conditions are checked.
3	green: ■ yellow: ☒ red: ☒	Aurora is powering the grid	Standard machine operation (search of max. power point or constant voltage).
4	green: ◻ yellow: ◻ red: ■	System insulation device faulty	Ground leakage found
5	green: ☒ yellow: ■ red: ☒	Defect – fault!!!	The Fault can be inside or outside the machine. See the alarm appearing on the LCD.
6	green: ☒ yellow: ◼ red: ☒	Installation phase: Aurora is disconnected from grid.	During installation, it refers to set-up of the address for RS-485 communication.
7	green: ☒ yellow: ■ red: ☒	Grid disconnection	Indicates a missing grid condition



NOTE: Inverter status is indicated by the corresponding LED turning steady on or flashing and by a display message that provides a description of current operation or fault condition (see next sections).

-
- G** 1) **Night time mode**
Y AURORA disconnected during night time; this occurs when input
R power is too low to feed the inverter.
- G** 2) **AURORA initialization and grid check**
Y Initialization in progress: input power sufficient to feed the
R inverter; AURORA is verifying start-up conditions (for instance:
input voltage value, insulation resistance value, etc.) and grid
check routine is launched.
- G** 3) **AURORA is feeding the grid**
Y After completing a set of electronics and safety auto-test routines,
R the inverter starts the grid connection process.
As mentioned above, during this stage AURORA automatically
tracks and analyzes the maximum power point (MPPT) of the
photovoltaic field.
- G** 4) **Ground insulation fault**
Y AURORA indicates that insulation resistance was found to be too
R low.
This may be due to an insulation fault in the connection between
the photovoltaic field inputs and the ground.



WARNING: Shock hazard! Do not attempt to correct this fault yourself. The instructions below have to be followed very carefully. In case you are not experienced or skilled enough to work safely on the machine, contact a specialized technician.

What to do after an insulation defect has been found

When the red LED turns on, try to reset the fault indication by pressing the multi-function ESC key at the side of the display. If AURORA reconnects to the grid, the fault was due to a transient event (such as condensation and moisture getting into the panels). If this trouble occurs frequently, have the system inspected by a specialized technician.

If AURORA does not reconnect to the grid, open both the DC and AC disconnect switches to place AURORA into a safe condition and contact an authorized service center to have the system repaired.

- G** **5) Malfunction/Fault indication**
Y Every time Aurora check system detects an operative malfunction
R or fault of the monitored system, the yellow LED comes on and a
message showing the type of problem found appears on the LCD.
- G** **6) RS-485 address setup indication**
Y During installation, the yellow LED will keep flashing until the
R address is acknowledged. For further information about address
entering, refer to section 6.3.
- 7) Grid disconnection**
G If a grid failure event occurs while the system is regularly
Y operating, the yellow LED turns on steady.
R

5.4 Messages and Error Codes

The system status is identified through message or error signals appearing on the LCD display.

The tables below summarise the two types of signals that can be displayed.

MESSAGES identify the AURORA current status; so they do not relate to faults and nothing has to be done. The message will disappear as soon as standard conditions are restored. See the Warning column (W) in the table below.

ERRORS identify a possible fault of the equipment or of the connected parts. The signal will disappear as soon as the causes are removed, except for the ground insulation fault on photovoltaic panels, for which the intervention of qualified personnel is required. Usually, when an error signal appears, an action is needed. This action will be managed as much as possible by AURORA or, in case this is not possible, AURORA will supply all the necessary information to assist the person fixing the fault on the equipment or system. See the Error column (E) in the table below.

Alarm n.	Message	Warning code	Error code	Description
1	Sun Low	W001	//	Input voltage under threshold (when OFF)
2	Input OC	//	E001	Input Over current
3	Input UV	W002	//	Input Undervoltage
4	Input OV	//	E002	Input Overvoltage
6	Int.Error	//	E003	No parametres
7	Bulk OV	//	E004	Bulk Overvoltage
8	Int.Error	//	E005	Communication error
9	Out OC	//	E006	Output Overcurrent
10	Int. Error	//	E007	IGBT Sat
11	Int.Error	//	E008	Bulk Undervoltage
12	Int.Error	//	E009	Internal error
13	Grid Fail	W003	//	Incorrect grid parametres
14	Int.Error	//	E010	Bulk Low
15	Int.Error	//	E011	Ramp Fail
16	DC/DC Fail	//	E012	DcDc error detected by the inverter
17	Not used in PVI-2000	//	E013	No parameters
18	-----	//	//	-----
19	Over Temp.	//	E014	Internal overtemperature
20	Cap. Fault	//	E015	Bulk capacitor fail
21	Inv. Fail	//	E016	Inverter fail detected by the DcDc
22	Int.Error	//	E017	Start Timeout
23	Ground F.	//	E018	Ileak fail
24	-----	//	//	-----
25	Int.Error	//	E019	Ileak sensor fail
26	DC/DC Fail	//	E012	DcDc error detected by the inverter
27	Int.Error	//	E020	inverter relay fail
28	Int.Error	//	E021	DcDc relay fail
29	Int.Error	//	E019	Ileak sensor fail
30	Int.Error	//	E022	Autotest Timeout
31	Int.Error	//	E023	Dc-Injection Error
32	Grid OV	W004	//	Output Overvoltage
33	Grid UV	W005	//	Output Undervoltage
34	Grid OF	W006	//	Output Overfrequency
35	Grid UF	W007	//	Output Underfrequency
36	Z Grid HI	W008	//	Z grid out of range
37	Int.Error	//	E024	Internal error
38	-----	//	E025	Low insulation resistance (log only)
39	Int.Error	//	E026	Wrong reference voltage (VRef)
40	Int.Error	//	E027	Wrong grid voltage measurement (VGrid)
41	Int.Error	//	E028	Wrong grid frequency measurement (FGrid)
42	Int.Error	//	E029	Wrong grid impedance

				measurement (ZGrid)
43	Int.Error	//	E030	Wrong leakage current measurement (ILeak)
44	Int.Error	//	E031	Wrong voltage measurement V
45	Int.Error	//	E032	Wrong current measurement I
46	Fan Fail	W010	//	Defective Fan (log only)
47	Int.Error	//	E033	Internal temperature

5.5 LCD Display

The 2-line LCD display is located on the front panel and shows:

- ✓ the status of the inverter and statistical data;
- ✓ service messages for the operator;
- ✓ messages of faults or damages found.

Data are shown cyclically, the screens change every 5 seconds. On the right of the display there is a button that when pressed freezes the screen. Pushing the button again unfreezes the screen. When AURORA is turned on the display shows the following screen for about 10 seconds:

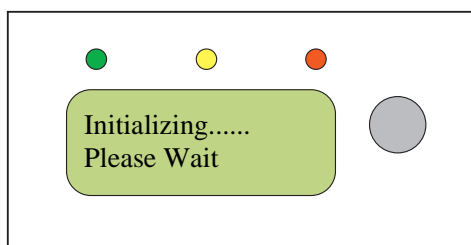

Afterwards it begins to check the grid. While checking the grid the display shows the three following screens cyclically:

- ✓ This screen shows how many seconds are left before a new grid connection Attempt will start

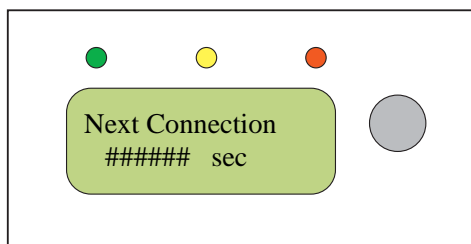

- ✓ The following screen shows the measured value of the insulation resistance:

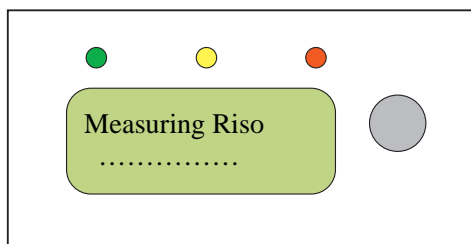

- ✓ This screen shows the grid voltage and the related status (in range or out of range).

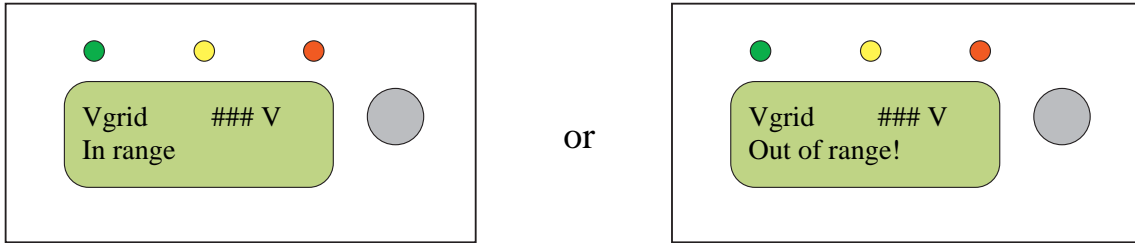

- ✓ This screen shows the grid frequency and the related status (in range or out of range, see section 9 for further details)

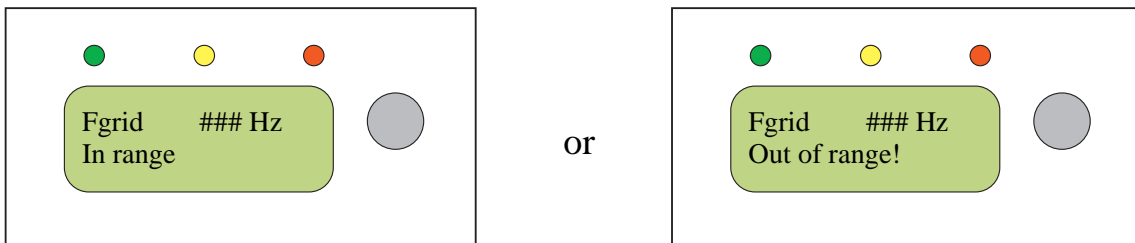

After AURORA is connected to the grid the display starts showing cyclically the following information screens, each for 5 seconds:

- ✓ First screen: Type and Part Number

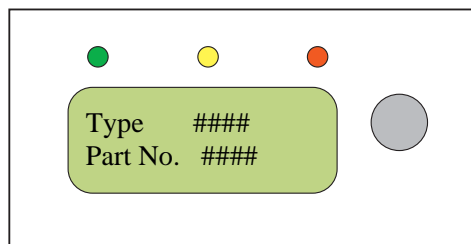

- ✓ Second screen: Serial Number and Firmware release number

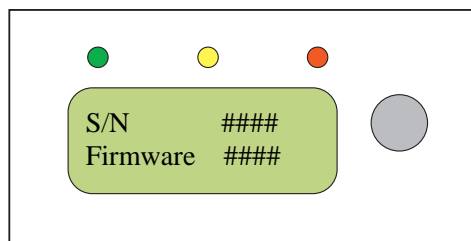

- ✓ Third screen: measured insulation resistance

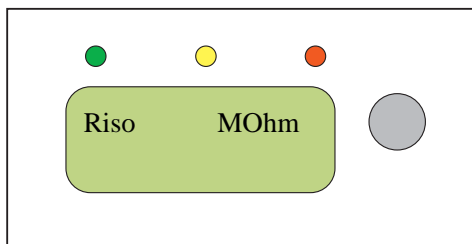

- ✓ Fourth screen: Output power and Voltage Input from the photovoltaic array

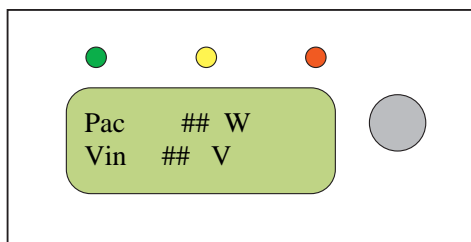

- ✓ Fifth screen: Total energy exported to the grid (E-Total) and total operating time (h-Total, that is time during which the unit was active). Both data are measured since the unit was first operated.

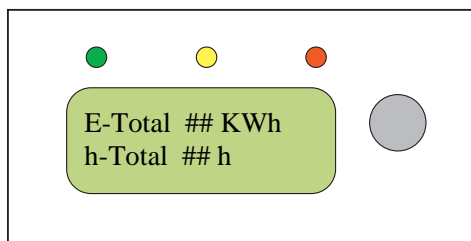

- ✓ Sixth screen: Time during which the unit exported energy to the grid (Timegrid) and number of times that unit connected to the grid (Numgrid).

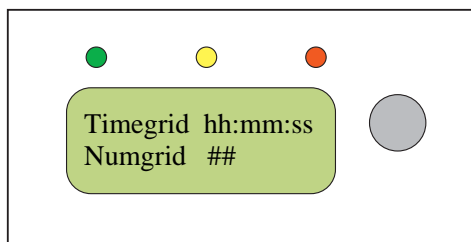

- ✓ Seventh screen: Daily energy (E-Today) and mode of operation of the inverter (ModeInverter)

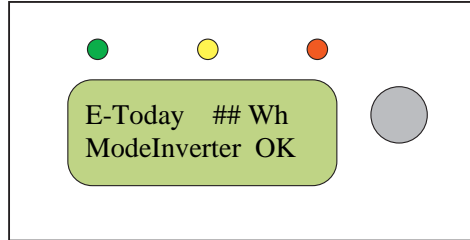

- Eighth screen: Leakage current (I-Leak)

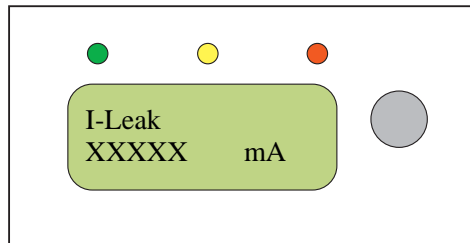

In case the inverter is not working properly the Fault or Ground Fault LEDs will turn on as described in paragraph 5.3, and the following three screens scroll on the LCD remaining on for 5 seconds. They contain important information that should be communicated to service personnel and will show cyclically on the LCD, each for 5 seconds:

- This screen shows the code of the error found, for further information refer to Chapter 5.4.

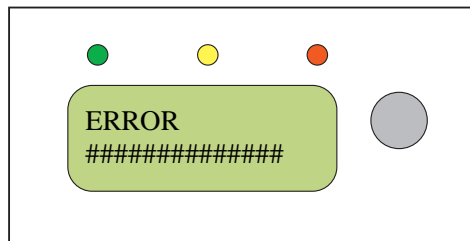

The sequence of the screens is summarized in the following figure:

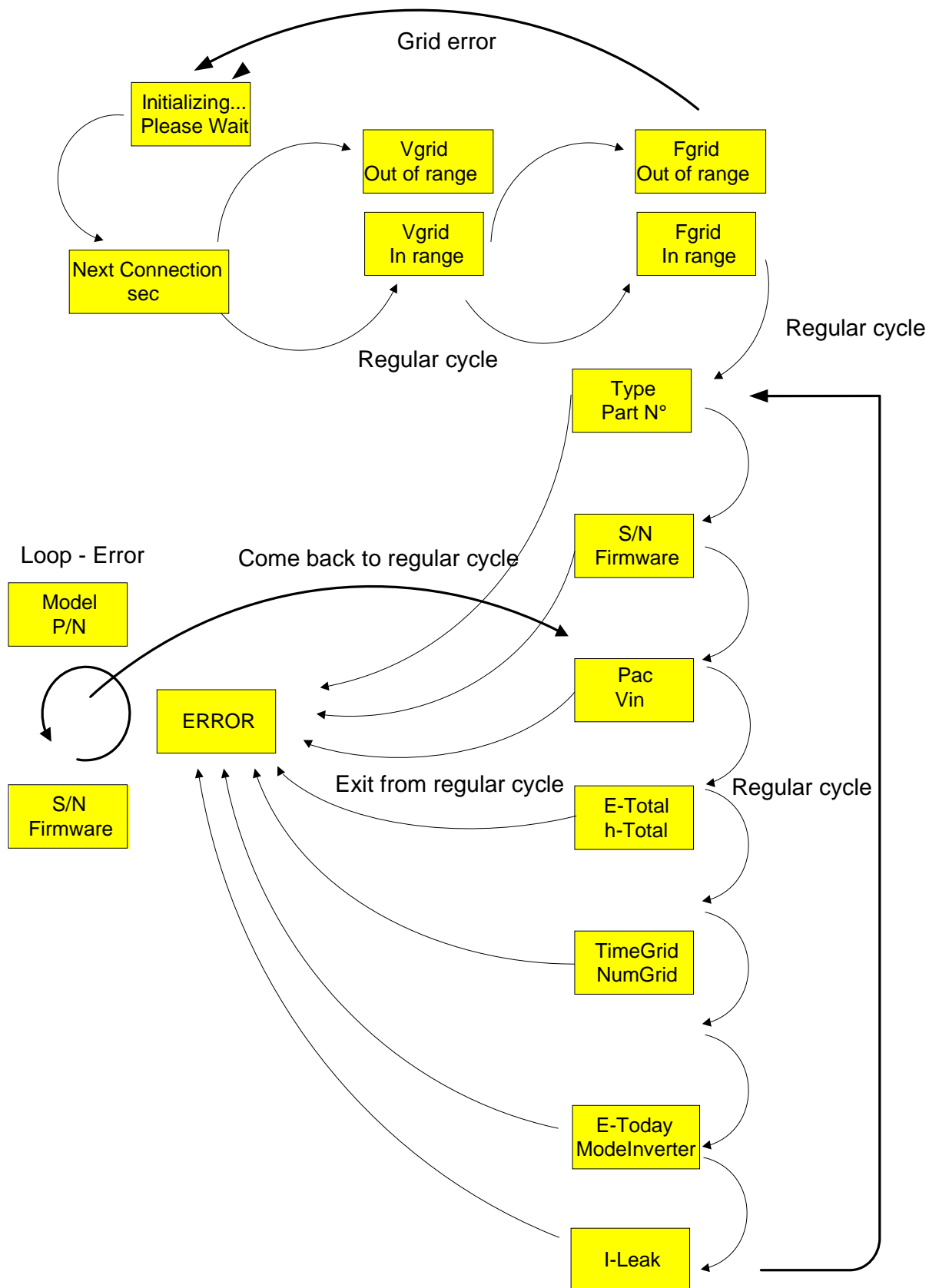

The values that can be displayed on the previous screens are summarized in the table below:

Data	Descrizione
Vin	Input voltage from photovoltaic array 1
Pac	Output Ac power
E-Total	Total energy transferred to the grid since the unit was first operated
E-Today	Total energy exported to the grid today
h-Total	Total time since the unit was first operated
Type	Type of AURORA
S/N	Serial Number
Part No°	Part Number
Firmware	Firmware release number
TimeGrid	Time during which the unit exported energy to the grid
NumGrid	Number of connections to the grid
Leakage	Leakage current

6 DATA CHECK AND COMMUNICATION

6.1 RS-485 serial link

The RS-485 link uses two wires for signals plus a third wire for signal grounding, which is different from the equipment grounding of the unit. The wires must be run in a watertight conduit through the bottom of the unit as explained in paragraph 3.5 after removing the watertight cap and installing a suitable watertight conduit connector.

A gasket with 2 holes is supplied together with the watertight conduit (cable gland PG16,5) in case multiple units are connected on the same RS485 link through a daisy chain. In case a single wire is used please stop the 2nd hole with the small white plug included in the kit.

The wires are then run to the RS-485 screw terminal blocks that is located in the internal compartment and is accessible by removing the right side panel. Please refer to paragraph 3.7 for further details on the correct procedure to remove and reposition the side panel.

- Signal wires must be connected to +T/R and –T/R terminals
- Grounding wire must be connected to the RTN terminal

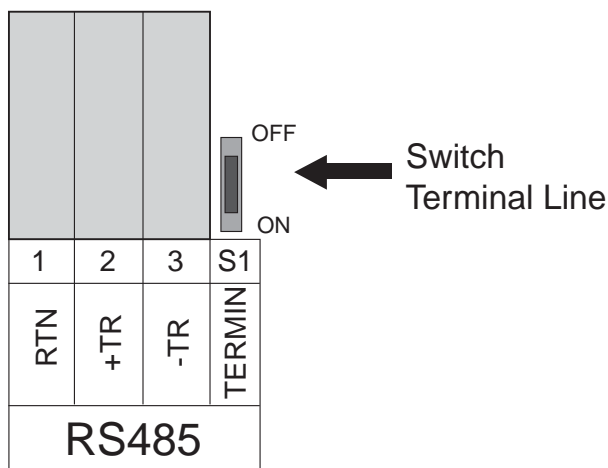

Fig. 16 RS-485 serial link terminal blocks

The single AURORA has a default address is two (2) and the S1 dip switch is in the OFF position (pushed away from the side access panel). The RS-485 address does not have to be configured for the single AURORA inverter.

Up to 31 AURORA inverters can be connected on the same RS-485 line. The maximum recommend RS-485 cable length is 1300 yards (1200 m).

In case multiple inverters are daisy-chained to the same RS-485 line, then the last unit must be terminated by changing the position of the dip-switch shown in Fig.16 from OFF to ON. The default position of the switch is OFF. Also, each unit must have a different address. See par. 6.2 to change the addresses.

In order for the RS485 communication line to perform the best, Power-one recommends to connect its PVI-RS232485 adapter before the first unit of the daisy-chain (see fig. 17 for details)

Equivalent devices may also be used for the same purpose, but they have not been tested therefore Power-one cannot grant the right functionalities.

Please also note that ordinary commercial adapters may need additional impedance termination. Aurora PVI-RS232485 adapter DOES NOT.

The following diagram shows how to connect multiple units on daisy-chain style in the same RS-485 bus.

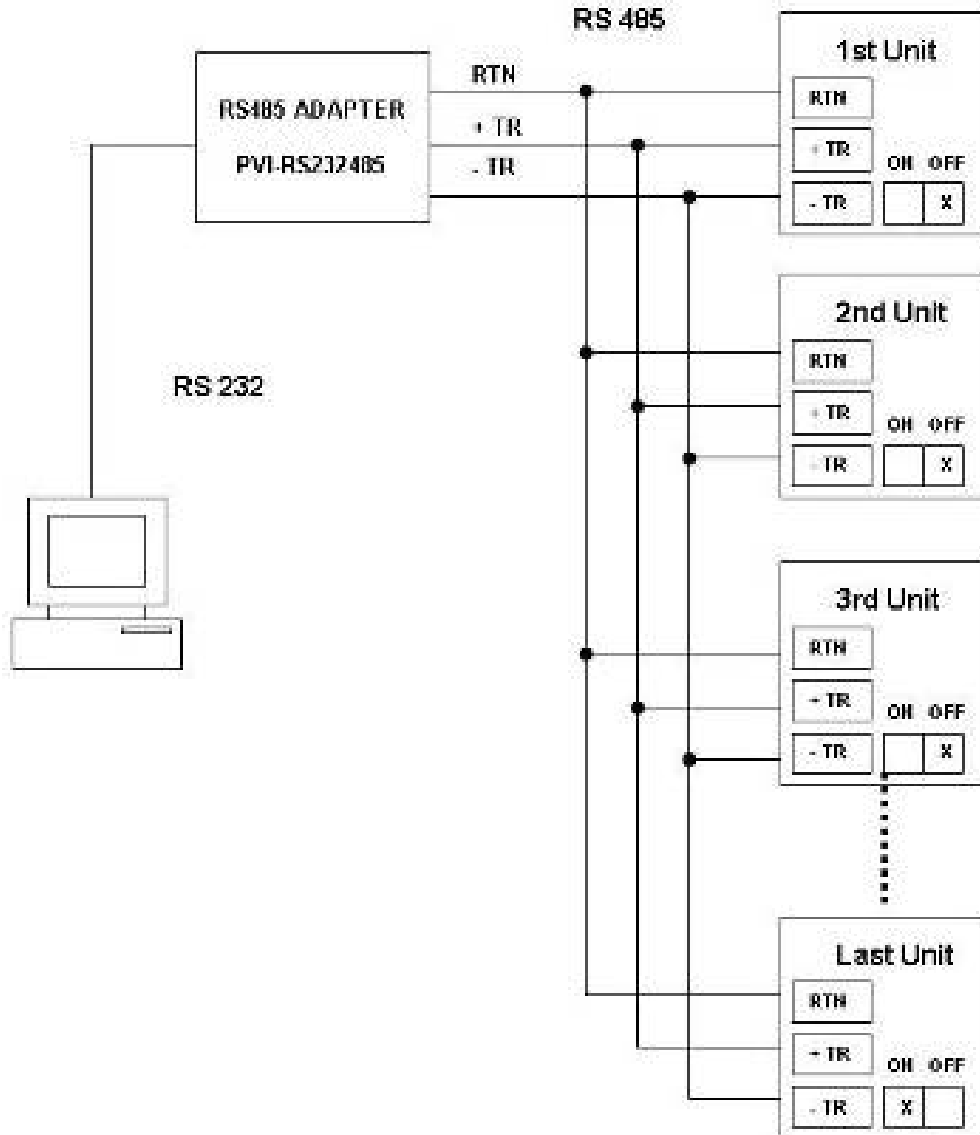

Fig.17 Multiple units connection daisy-chain style



NOTE: When using the RS-485 link there can be no more than 31 inverters connected on the same link. Although you are free to choose any address between 2 and 63, we recommend using addresses between 2 and 34 for the RS-485 serial link.



NOTE When using the RS-485 link, in case one or more inverters are later added to the system; please remember to bring the dip switch that was the last of the system back to OFF.

6.2 Address selection

When several inverters are connected to the same communication channel each unit must have a different address. The default address of each unit is 2. To assign a new address the following information must be taken into account:

- Addresses 0 and 1: are reserved for host computers and monitoring accessories such as Easy Controller display unit.
- The RS-485 serial link uses addresses from 2 to 34

Use the following procedure to set the new address:

1) Press the key on the side of the LCD display button for at least 5 seconds

2) AURORA disconnects from the grid, the yellow LED begins to blink and the display shows:

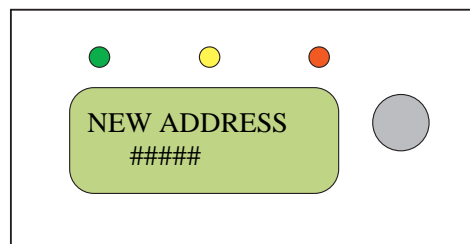

3) Press the key as many times as needed to select the address between 2 and 63. After the 63 the address starts back from 0.



WARNING: Do not use the “AUTO” address. The automatic setting of the addresses through this key is a procedure reserved exclusively to installers and qualified personnel as it requires the use of a specific software.

4) Confirm the choice by pressing once more the key for at least 5 seconds. After the confirmation AURORA connects again to the grid.

6.3 Baud Rate setting

1) After the inverter address have been defined according to the procedure included in paragraph 6.2, if the button at the right side of the LCD is pushed continuously for at least 5 sec and then released the display menu enters in the Baud Rate setting.

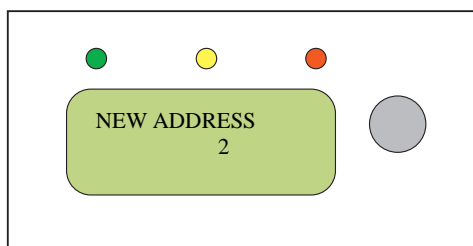

2) The display will show the wording "SET BAUD RATE" and the default baud rate setting of: 19200

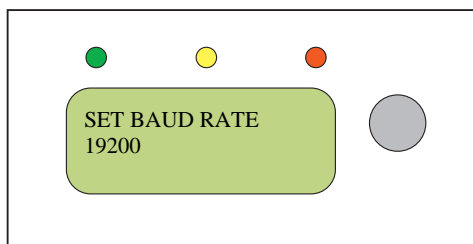

3) To confirm the baud rate setting displayed just push the button firmly for another 5 sec period.

4) conversely to show the other baud rate setting options just shortly push the button.

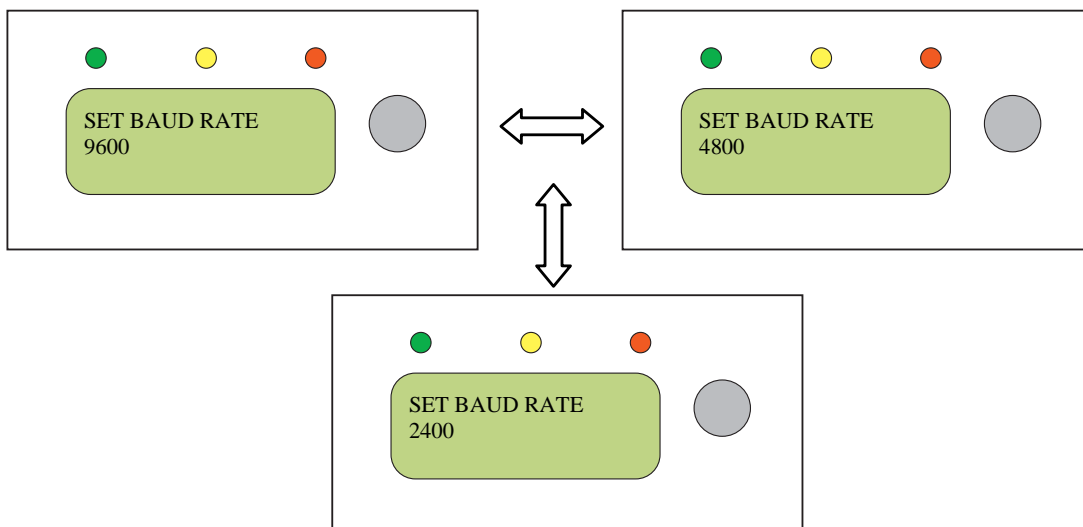

5) To confirm the selected baud rate that appear on the display keep the button firmly pushed for at least 5 sec..

WARNING: In general the standard baud rate is at 19200. Only in case of long distance or noisy transmission lines it is recommended to slow down the baud rate.

6.4 Measurement Accuracy

Every measurement device can be affected by errors.

For each measurement the tables below show the following information:

- Measurement Unit;
- Delivery rate;
- Resolution.

	Data	Unit	Resolution		Max error
			Display	Measurement	
Output voltage PV	VP1	Vdc	1 V	600mV	2%
Output current PV	IP1	Adc	0.1 A	15mA	2%
Power PV	Pin1	W	1 W	10W	2%
Output voltage	Vout	V	1 V	-	2%
Output current	Iout	A	0.1 A	-	2%
Output power	Pout	W	1 W	-	2%
Frequency	Freq	Hz	0,01	0,01	0,1%
Energy produced	Energy	Wh	1 Wh	-	4%
Tot. time counter	Lifetime	hh:mm:ss	1 s		0,2%
Partial time counter	Partial Time	hh:mm:ss	1 s		0,2%

7 TROUBLESHOOTING

AURORA inverters comply with standards set for grid-tied operation, safety and electromagnetic compatibility.

Before being delivered by Power-One, the product has undergone successfully to several tests to check: operation, protective devices, performance and durability.

All these tests, together with the system ensuring Power-One quality, guarantee an optimal operation of AURORA.

However, should any malfunction of the photovoltaic system arise, solve problems as follows:

- ✓ Work under safe conditions as stated in chapter 3.5 and following. Make sure that the connections between AURORA, the photovoltaic field and power distribution grid have been made correctly.
- ✓ Carefully observe which LED is blinking and read the signal appearing on the display; then, following the instructions given in chapters 5.4 and 5.5 try to identify the type of fault found.

If the malfunction cannot be removed by following these instructions, contact the service centre or the installer (see following page).

Before contacting the service centre, keep the following information close at hand, to maximise efficiency of intervention:

AURORA INFO



NOTE: Information to be found directly on the LCD display

- ✓ AURORA model?
 - ✓ Serial number?
 - ✓ Week of production?
 - ✓ LED flashing?
 - ✓ Light blinking or steady?
 - ✓ Which signal is shown on the display?
-
- ✓ Short description of the malfunction
 - ✓ Can the malfunction be reproduced?
 - ✓ If so, how?
 - ✓ Does the malfunction appear cyclically?
 - ✓ If so, how frequently?
 - ✓ Is malfunction present from installation?
 - ✓ If so, has it worsened?
 - ✓ Description of the weather conditions at the time the malfunction appeared

INFO on the Photovoltaic Field

- ✓ Make and model of photovoltaic panels
- ✓ System structure:
 - number of arrays and max. voltage and current values
 - number of strings for each array
 - number of panels for each string

8 TECHNICAL FEATURES

8.1 Input Values



WARNING: the Photovoltaic field and system wiring must be configured so that the PV input voltage is less than the maximum upper limit independently from the type, the number and the operating conditions of the chosen photovoltaic panels.

As panel voltage also depends on working temperature, the number of panels per string shall be chosen according to the min. ambient temperature expected in that special area (see table A).



WARNING: The inverter has a linear power derating related to the input voltage, starting from 530 Vdc (100% output power) to 580 Vdc (0% output power)



WARNING: The open circuit voltage of the photovoltaic panels is affected by the ambient temperature (the open circuit voltage increases as the temperature decreases). Make sure that at the minimum temperature estimated for the installation does not cause the panels to exceed the maximum upper limit of 600Vdc. As an example, the following table shows for typical panels of 36, 48 and 72 cells, the maximum voltage of each panel as function of the temperature (assuming a nominal open circuit voltage of 0.65Vdc at 25°C and a temperature coefficient of 0,0023V/°C). The table shows, therefore, the maximum number of panels that can be connected in series as a function of the minimum temperature at which the system will operate. Consult the panel manufacturer for the correct temperature coefficient of V_{oc} , before calculating the voltage rating of the photovoltaic array.

Minimum Panel Temp. [°C]	36 Cells Panels		48 Cells Panels		72 Cells Panels	
	Panel voltage	Max number of panels	Panel voltage	Max number of panels	Panel voltage	Max number of panels
25	21.6	27	28.8	20	43.2	13
20	22.0	27	29.4	20	44.0	13
15	22.4	26	29.9	20	44.9	13
10	22.8	26	30.5	19	45.7	13
5	23.3	25	31.0	19	46.5	12
0	23.7	25	31.6	19	47.3	12
-5	24.1	24	32.1	18	48.2	12
-10	24.5	24	32.7	18	49.0	12
-15	24.9	24	33.2	18	49.8	12
-20	25.3	23	33.8	17	50.7	11
-25	25.7	23	34.3	17	51.5	11

✓ Table A

Description	Value PVI – 2000-OUTD
Nominal input voltage	360Vdc
Input voltage range	from 90 Vdc to 600 Vdc
Input voltage, MPPT operating range	from 90 Vdc to 580 Vdc
Input voltage, MPPT range at full power	from 220 Vdc to 530 Vdc
Minimum input voltage for grid connection	200Vdc
Max. short circuit current	12 Adc
Max. operating input current	10 Adc
Max. input power	2200 W
PV Ground fault protection	Ground fault detection and shut off provided
Array configuration	One array



NOTE: If the input current supplied by the photovoltaic field connected to the inverter is above the max. value and the input voltage is within the allowed range, the inverter is not damaged.

8.2 Output Values

Description	Value PVI – 2000-OUTD
Nominal output power	2000 W
Grid voltage maximum range	from 200 to 270 Vac
Nominal grid voltage	230 Vac
Grid voltage, operating range in compliance to AS4777	from 89% to 115% of nominal voltage (from 205 to 264Vac for $V_{nom}=230Vac$)
Grid frequency, maximum range	from 45 to 55 Hz
Grid frequency, nominal	50 Hz
Grid frequency, operating range in compliance to AS4777	from 47.1 to 52.9 Hz
Current output, nominal	9 Arms
Output over current protection	11 Arms

8.3 Grid protection characteristics

Anti islanding protection	In compliance to: - AS4777.3-2005
---------------------------	--------------------------------------

8.4 General characteristics

Description	Value PVI – 2000-OUTD
Maximum efficiency	96%
Internal consumption during stand-by	< 8 W
Internal consumption during night time	< 0.30 W
Operating ambient temperature	from -25°C to +60°C (from -13°F to 140°F)
Enclosure protection level	IP65 / Nema 4X
Audible Noise	< 30dBA @ 1m with fans off < 50 dBA @ 1m with fans max speed
Dimensions (H x W x D):	420 x 310 x 144 mm
Weight	12 kg

8.5 Power Derating

To ensure a safe operation of the inverter under any temperature and electrical condition, the unit will automatically derate the power to be supplied to the grid. Power derating can occur on one of the following occasions:

Power Derating due to Ambient Temperature

Natural convection cooling system of Aurora guarantees high reliability and keeps the internal components within the optimal operating temperature range.

Under severe operating conditions (when ambient temperature is very high), the unit may need to reduce the power supplied.

Several environmental factors can influence the operating temperature of the unit, such as ambient air temperature, airflow, exposure to sun radiation, input voltage and power, orientation of the heatsink fins, etc.

AURORA is able to supply the maximum rated output power (i.e. 2.000W) with ambient temperatures up to 40°C, in case the unit is not directly exposed to solar radiation or heat sources that may cause a further increase of the internal temperature.

Power Derating due to Input Voltage

The graph shows the automatic derating of the power supplied when input voltage values are too high or too low.

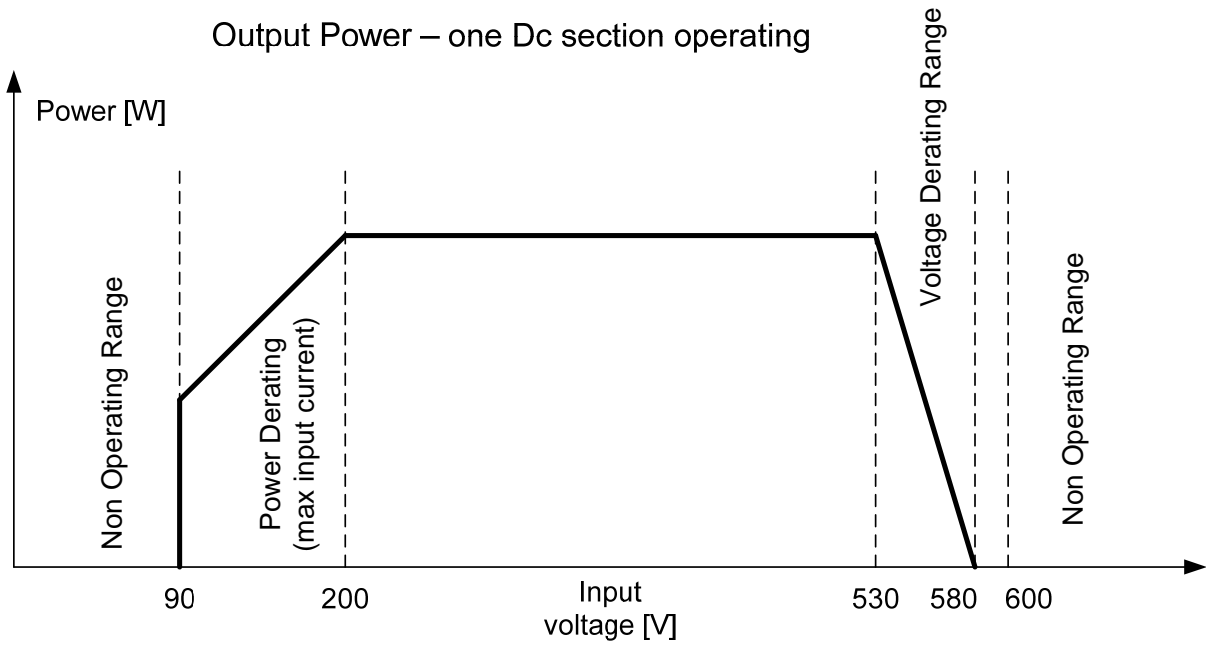

Fig. 18

***** CERTIFICATES OF COMPLIANCE *****